

# Advanced Sensors

Databook

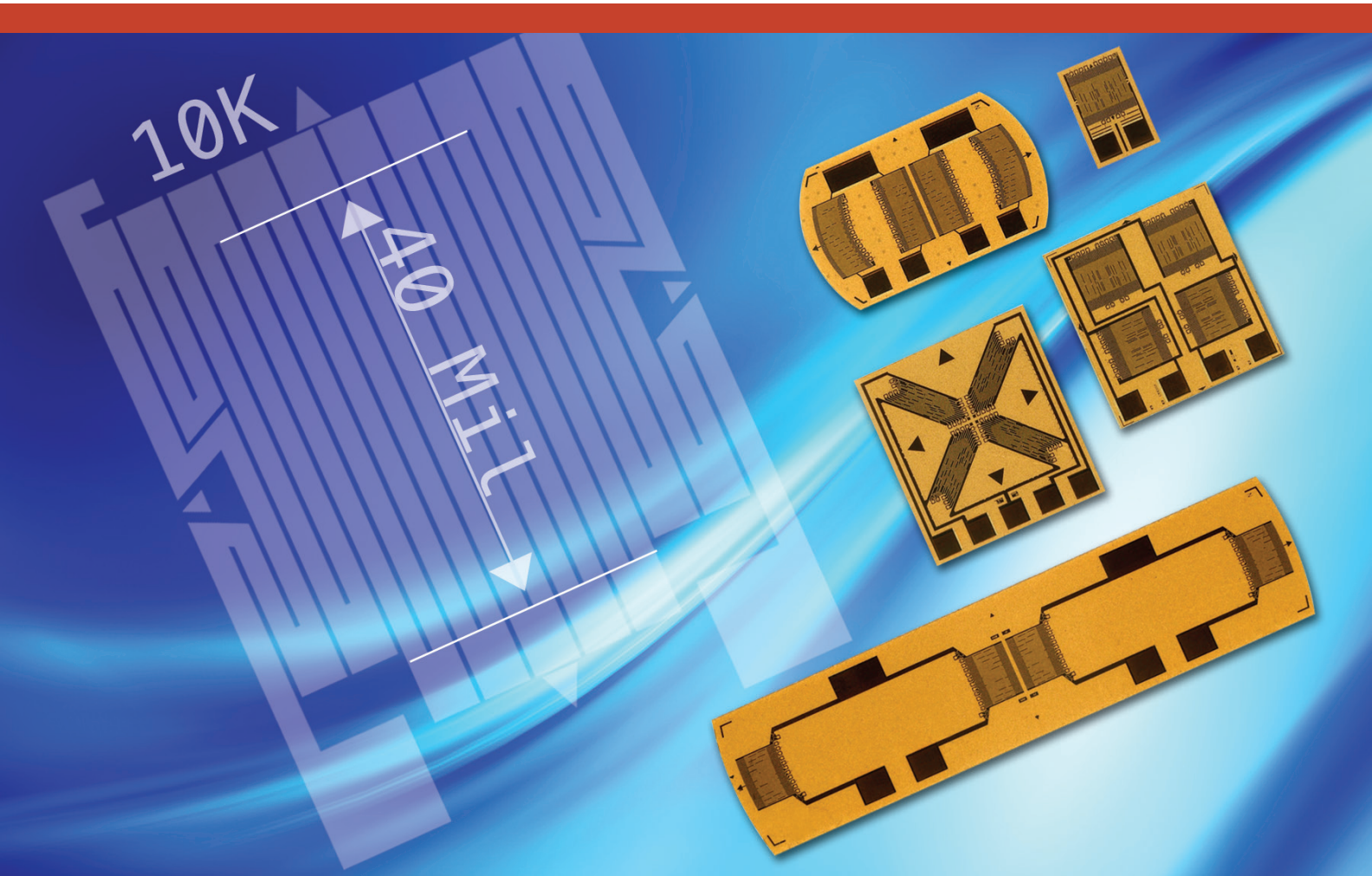

Strain Gage Sensors  
Bondable Resistors

# **Advanced Sensors and Bondable Resistors**

**Micro-Measurements**

P.O. Box 27777

Raleigh, NC 27611

U.S.A.

Phone: +1-919-365-3800

Fax: +1-919-365-3945

**[www.micro-measurements.com](http://www.micro-measurements.com)**

## Disclaimer

ALL PRODUCTS, PRODUCT SPECIFICATIONS AND DATA ARE SUBJECT TO CHANGE WITHOUT NOTICE.

Vishay Precision Group, Inc., its affiliates, agents, and employees, and all persons acting on its or their behalf (collectively, "VPG"), disclaim any and all liability for any errors, inaccuracies or incompleteness contained herein or in any other disclosure relating to any product.

The product specifications do not expand or otherwise modify VPG's terms and conditions of purchase, including but not limited to, the warranty expressed therein.

VPG makes no warranty, representation or guarantee other than as set forth in the terms and conditions of purchase. **To the maximum extent permitted by applicable law, VPG disclaims (i) any and all liability arising out of the application or use of any product, (ii) any and all liability, including without limitation special, consequential or incidental damages, and (iii) any and all implied warranties, including warranties of fitness for particular purpose, non-infringement and merchantability.**

Information provided in datasheets and/or specifications may vary from actual results in different applications and performance may vary over time. Statements regarding the suitability of products for certain types of applications are based on VPG's knowledge of typical requirements that are often placed on VPG products. It is the customer's responsibility to validate that a particular product with the properties described in the product specification is suitable for use in a particular application. You should ensure you have the current version of the relevant information by contacting VPG prior to performing installation or use of the product, such as on our website at [vpgsensors.com](http://vpgsensors.com).

No license, express, implied, or otherwise, to any intellectual property rights is granted by this document, or by any conduct of VPG.

The products shown herein are not designed for use in life-saving or life-sustaining applications unless otherwise expressly indicated. Customers using or selling VPG products not expressly indicated for use in such applications do so entirely at their own risk and agree to fully indemnify VPG for any damages arising or resulting from such use or sale. Please contact authorized VPG personnel to obtain written terms and conditions regarding products designed for such applications.

Product names and markings noted herein may be trademarks of their respective owners.

General Information.....	5
Gage Series.....	7
Creep and Modulus Compensation .....	9
Designation System .....	10
Linear Patterns—Single Grid.....	11
Linear Patterns—Dual Grid .....	23
90° Patterns.....	32
Shear Patterns—Single Grid .....	43
Shear Patterns—Dual Grid.....	47
Full-Bridge Patterns .....	56
Linear Diaphragm Patterns.....	65
Circular Diaphragm Patterns.....	69
Bondable Resistor Patterns .....	71





## ***Transducer-Class*<sup>®</sup> Strain Gages with Advanced Sensors Technology**

Micro-Measurements has been a trusted name in the field of strain gage technology for more than 60 years. We are proud of our worldwide reputation as a premier supplier of high-quality precision strain gages and strain gage accessories, and are fully committed to maintaining our position as the leader in this field. This catalog of Micro-Measurements *Transducer-Class*<sup>®</sup> strain gages and related products for OEM applications is intended to provide an overview of the sensors and installation accessories and tools needed for successful transducer strain gage applications.

### **TRANSUCER-CLASS WITH ADVANCED SENSORS TECHNOLOGY**

The *Transducer Class* strain gages are built with our advanced sensors technology, using state-of-the-art equipment and tooling for excellent performance and reduced lead times. Exclusive features of *Transducer-Class* gages with advanced sensors technology include:

- Excellent gage-to-gage and grid-to-grid matching, to allow for more uniform gage performance in temperature.
- Tighter resistance tolerances: down to  $\pm 0.1\%$  even in high resistance gage patterns, enables simpler balance of the Wheatstone bridge circuitry.
- High resistance patterns: offered in linear, shear, tee-patterns and full-bridge configurations, with up to 10 Kohm resistance values.
- Gold-plated solder tabs (on Karma foil patterns) and epoxy encapsulation for active grid protection offered as standard features.
- Targeted to support high-volume OEM applications using state-of-the-art innovative technology.
- Optimum backing thickness tolerance, particularly important to minimize creep variations between gage installations.
- Multiple creep compensation choices for most gage patterns. A close inspection of the gage pattern reveals a small letter on the gage matrix next to the grid. This letter is the creep compensation code. Different creep compensations of the same pattern can be easily identified after removing gages from the package.
- Special pattern refinement for improved gage-to-gage reproducibility. Creep variation due to operating temperature changes is reduced.

### **INSTALLATION ACCESSORIES**

Construction of the strain gage is completed when it is bonded and wired—final manufacturing steps that our customers undertake. To help ensure successful transducers, Micro-Measurements accessories are extensively tested before being selected for strain gage use. Clear, concise instructions are provided to make these final manufacturing steps as risk-free as possible.

### **APPLICATIONS ASSISTANCE**

Our Transducer Applications Department is dedicated to providing accurate, friendly and confidential answers to your strain gage application questions. With a fully equipped laboratory and all of Micro-Measurements' combined engineering, manufacturing, and applications experience available to them, our Applications Engineers are "on-call" for you.

Individualized customer training is available in our Applications Laboratory or Technical Training Center in Raleigh, North Carolina USA.



## Transducer-Class® Strain Gages with Advanced Sensors Technology

### REFERENCE LITERATURE

Technical and product literature, along with special publications like our *Strain Gage Based Transducers* booklet, are available at no charge.



### CUSTOMER SERVICE

We know that we must deliver in order for you to produce. Our Customer Service Department works daily with the individual requirements of our *Transducer-Class* customers to make sure that we supply the product you need—when you need it. Purchase conditions are tailored to your requirements, optimizing price/performance and minimizing inventory costs while ensuring the supply of reliable, high-quality strain gages and accessories.



**Transducer-Class® Strain Gages with Advanced Sensors Technology**

**N2A SERIES**

N2A gages are constantan-alloy patterns constructed on a thin, laminated, polyimide-film backing. This series is capable of low and repeatable creep performance. Construction is very rugged, which will help prevent gage handling damage. Advanced Sensors N2A gages are offered with epoxy encapsulation as standard. An open-faced version can be supplied upon request.

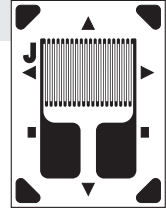

**J2A SERIES**

J2A gages are encapsulated constantan-alloy patterns. Both the encapsulation and backing are thin, laminated polyimide film. Gage soldering tabs are exposed for simplified lead connections. Creep performance is equal to the N2A Series, although the presence of an encapsulating layer will require a change in creep code selection to maintain the same performance.

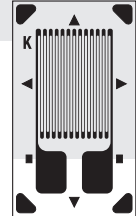

**EA SERIES**

EA gages are open-faced constantan-alloy patterns with a flexible cast-polyimide backing. Creep scatter is somewhat more pronounced than with all other series. Consequently, EA gages are normally available with only one creep code per pattern.

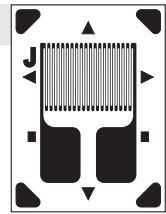

**N2K SERIES**

N2K gages are modified-Karma-alloy patterns constructed on a thin, laminated, polyimide-film backing. All N2K gages are supplied with gold soldering pads (DG) for ease of leadwire attachment. Copper soldering pads are also available. Most gages in the N2K Series can also be modulus compensated. Advanced Sensors N2K gages are offered with epoxy encapsulation as standard. An open-faced version can be supplied upon request.

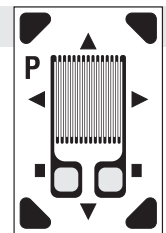

**N5K SERIES**

N5K gages are modified-Karma-alloy patterns constructed on a thin, laminated, polyimide-film backing constructed to improve gage performance at elevated temperatures. All N5K gages are supplied with gold soldering pads (DG) for ease of leadwire attachment. Copper soldering pads are also available. Most gages in the N5K Series can also be modulus compensated. Advanced Sensors N5K gages are offered with epoxy encapsulation as standard.

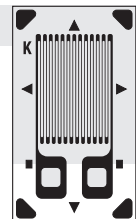

**J5K SERIES**

J5K gages are encapsulated, modified-Karma-alloy patterns specially constructed to improve gage performance at elevated temperatures. Because of the laminated polyimide-film backing and encapsulation, all J5K patterns are fully flexible without being brittle. Gold soldering pads (DG) as well as copper soldering pads (DP) are exposed for simplified lead connections. Some J5K gages can be supplied with modulus-compensation (EMC) options. For best high-temperature performance, J5K-Series gages should be installed with M-Bond 450 high-temperature adhesive.

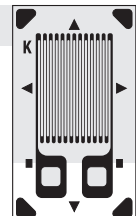

## Transducer-Class® Strain Gages with Advanced Sensors Technology

### J5E SERIES

J5E gages are a family of platinum-tungsten-alloy patterns constructed with a thin, flexible polyimide backing. Sensing grids are fully encapsulated by a polyimide film overlay and include a preformed solder dot on each gage tab. With a gage factor more than double that of conventional strain gages, platinum-tungsten-alloy patterns provide standard transducer output levels at less than half the normal spring-element stress values. This allows for higher overload safety, increased fatigue life, and improved linearity in many transducer designs. A negative gage-factor-versus-temperature slope also provides modulus compensation in many types of steel transducer spring elements. A relatively high thermal output of platinum-tungsten alloy makes precision static measurements difficult. J5E gages are not manufactured with the Advanced Sensors Technology

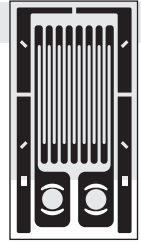

GAGE SERIES	TEMPERATURE RANGE		GAGE FACTOR (SEE NOTE)	FATIGUE LIFE	
	STATIC	DYNAMIC		STRAIN LEVEL IN $\mu\epsilon$	NUMBER OF CYCLES
N2A	-100° to +200°F (-75° to +95°C)	Same as Static	2.05 nom.	$\pm 1500$ 1500	$10^7$ $10^8$ <sup>(2)</sup>
J2A	-100° to +200°F (-75° to +95°C)	Same as Static	2.05 nom.	$\pm 1700$ 1700	$10^6$ $10^7$ <sup>(2)</sup>
EA	-100° to +200°F (-75° to +95°C)	-320° to +350°F (-75° to +95°C)	2.05 nom.	$\pm 1500$ 1500	$10^6$ $10^7$ <sup>(2)</sup>
N2K	-100° to +200°F (-75° to +95°C)	Same as Static	2.1 nom. <sup>(1)</sup>	$\pm 1800$	$10^7$
N5K	-100° to +400°F (-75° to +205°C)	-320° to +500°F (-195° to +260°C)	2.1 nom. <sup>(1)</sup>	$\pm 1800$	$10^7$
J5K	-100° to +400°F (-75° to +205°C)	-320° to +500°F (-195° to +260°C)	2.1 nom. <sup>(1)</sup>	$\pm 2000$ 1800	$10^7$ $10^8$ <sup>(2)</sup>
J5E	-100° to +400°F (-75° to +205°C)	Same as Static	4.5 nom.	$\pm 1500$	$10^8$

#### Notes:

Advanced Sensors gages are supplied with nominal gage factor values that will vary slightly with pattern. They are not suitable for strain measurement in stress analysis applications. Request our Precision Strain Gages databook, or contact our Applications Engineering Department, for a complete listing of gages for precision strain measurement applications.

<sup>(1)</sup> Nominal gage factor is 2.2 for EMC options.

<sup>(2)</sup> Unidirectional strain.



## Advanced Sensors

### CREEP COMPENSATION

Commercial transducers regularly achieve a creep specification of less than  $\pm 0.02\%$  of full scale (FS) for a 20-minute test. To attain this level on a high production basis, it is usually necessary to match the strain gage's creep characteristic to the spring element creep.

Most *Transducer-Class* gages can be adjusted in design to exhibit either a positive or negative creep under load. Spring element materials exhibit only positive creep under load. (See figure below.)

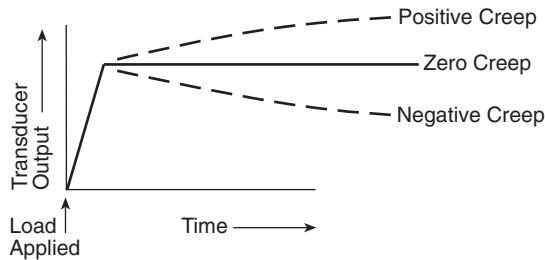

Since transducer creep depends on several variables such as spring element material, heat treatment, strain field, adhesive type and test temperature, it is not possible to predict the proper gage compensation necessary to achieve the best creep result.

Most of the gages in this catalog list one available creep compensation code. Since it is not possible to predetermine the creep characteristics of a particular transducer, it is suggested that the standard creep code be ordered in quantities sufficient to evaluate three or four transducers. Where creep levels are high enough to warrant correction, a different creep compensation, either more negative or more positive, depending on test results, can often be recommended.

A complicating factor in creep code selection is that while different gage patterns may list the same creep code, they do not necessarily exhibit the same creep behavior. This is because the gage backing selection, gridline width and gage length also influence creep characteristics.

It should also be noted that this type of creep correction is generally limited to transducers exhibiting less than  $\pm 0.1\%$  FS creep. Higher creep levels in the positive direction are often the result of poor spring element material selection. Negative creep values in excess of  $0.1\%$  FS generally are the result of a faulty gage installation.

### MODULUS COMPENSATION (EMC) OPTION

Many of the K-alloy gages in this catalog are available in a special form which permits the gage factor change with temperature to be adjusted over a wide range during gage manufacture.

Properly matched to the transducer spring element, these EMC (Effective Modulus Compensation) gages can provide very good self-correction of changes in transducer span versus temperature. A compensation better than  $\pm 0.0008\%/^{\circ}\text{F}$  ( $\pm 0.0014\%/^{\circ}\text{C}$ ) can readily be achieved in many cases.

While this may at first appear to be the "ideal" strain gage for transducers, there are certain factors that should be considered prior to selecting EMC gages for a given application:

1. EMC gages cost more than other gages. In most cases the difference is great enough to offset the additional cost of span/temperature resistors.
2. EMC gages must be "matched" to the transducer spring material. Depending on the degree of compensation accuracy desired, the standard EMC options may not yield the "best fit" compensation on the spring material in use. In these cases, a special foil lot which possesses the desired compensation would be required. There is normally a minimum order requirement and set-up charge for special foil lots.
3. Transducer spring materials may not have batch-to-batch repeatability sufficient to maintain specifications when using the same EMC gages. New material lot testing is therefore necessary for high precision units.

Despite these limitations, EMC gages can often be advantageous for transducer manufacturers.

The following standard EMC options are available:

#### OPTION M1

Gage factor slope is  $-1.50\%$  per  $100^{\circ}\text{F}$  ( $-2.70\%$  per  $100^{\circ}\text{C}$ ). Provides span-versus-temperature compensation for many stainless steels.

#### OPTION M2

Gage factor slope is  $-2.35\%$  per  $100^{\circ}\text{F}$  ( $-4.23\%$  per  $100^{\circ}\text{C}$ ). Provides span-versus-temperature compensation for most aluminum alloys.

#### OPTION M3

Gage factor slope is  $-1.25\%$  per  $100^{\circ}\text{F}$  ( $-2.25\%$  per  $100^{\circ}\text{C}$ ). Provides span-versus-temperature compensation for many tool steels.

#### OPTION M4

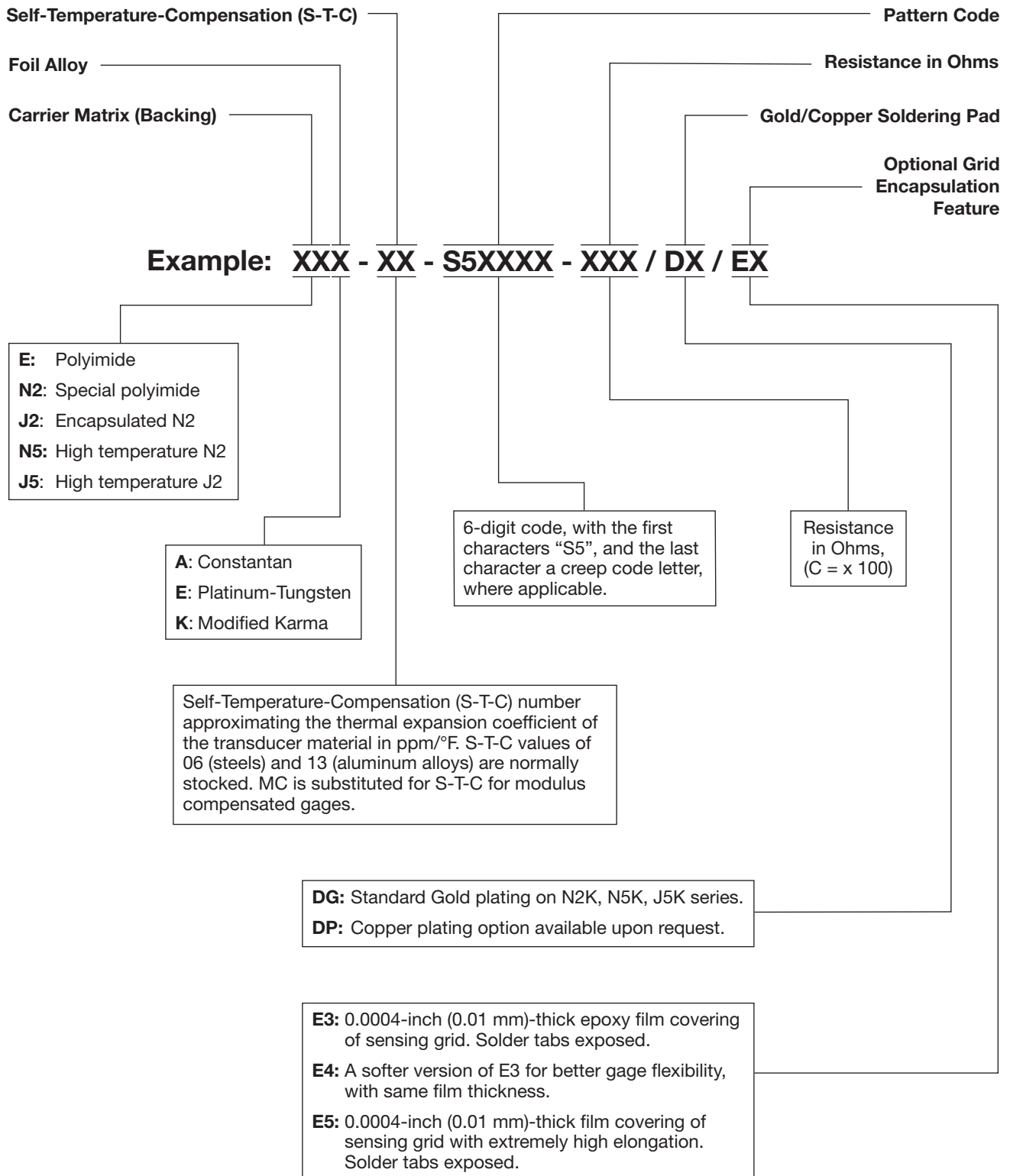

Gage factor slope is  $-1.35\%$  per  $100^{\circ}\text{F}$  ( $-2.43\%$  per  $100^{\circ}\text{C}$ ). Provides "mid-range" compensation between M1 and M3.

## Transducer-Class® Strain Gages with Advanced Sensors Technology





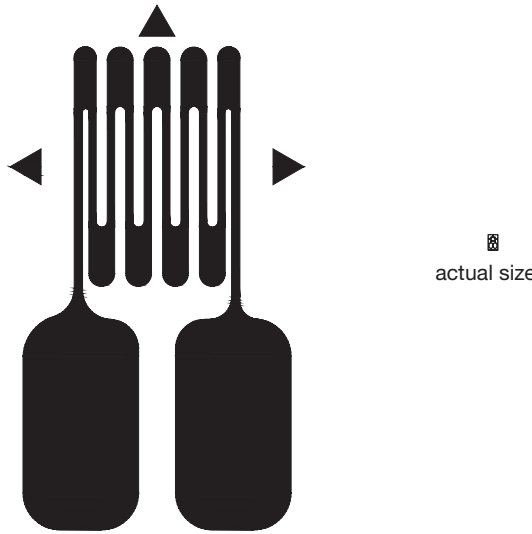

**Transducer-Class® Strain Gages with Advanced Sensors Technology**

<b>S5272 GAGE PATTERN DATA</b>			
	<b>GAGE DESIGNATION</b>	<b>RESISTANCE IN OHMS</b>	<b>STD. CREEP CODE</b>
	N2A-XX-S5272H-120/E4	120 ±0.5%	H*
<b>DESCRIPTION</b>			
General-purpose miniature pattern 120 Ω.			

<b>GAGE DIMENSIONS</b>						<b>inch</b>	<b>millimeter</b>
<b>Gage Length</b>	<b>Overall Length</b>	<b>Grid Width</b>	<b>Overall Width</b>	<b>Matrix Length</b>	<b>Matrix Width</b>		
0.015	0.062	0.020	0.037	0.08	0.05		
0.38	1.57	0.51	0.93	2.1	1.2		

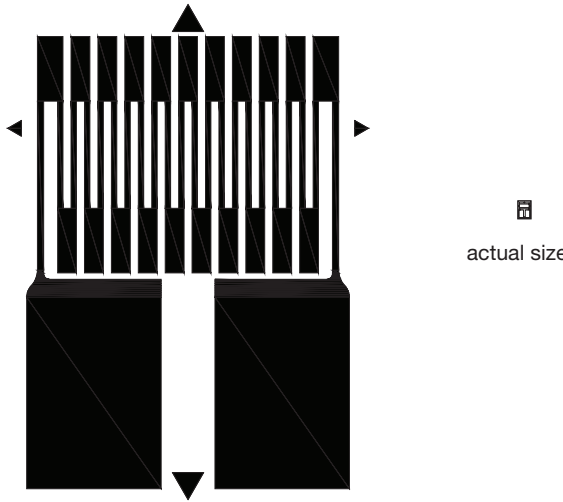

\* Only creep code available for this gage.

<b>S5077 GAGE PATTERN DATA</b>			
	<b>GAGE DESIGNATION</b>	<b>RESISTANCE IN OHMS</b>	<b>STD. CREEP CODE</b>
	N2K-XX-S5077T-350/DG/E5 N5K-XX-S5077T-350/DG/E5	350 ±0.2% 350 ±0.2%	T T
<b>DESCRIPTION</b>			
General-purpose miniature pattern 350 Ω.			

<b>GAGE DIMENSIONS</b>						<b>inch</b>	<b>millimeter</b>
<b>Gage Length</b>	<b>Overall Length</b>	<b>Grid Width</b>	<b>Overall Width</b>	<b>Matrix Length</b>	<b>Matrix Width</b>		
0.020	0.089	0.060	0.060	0.10	0.07		
0.51	2.26	1.52	1.52	2.5	1.8		

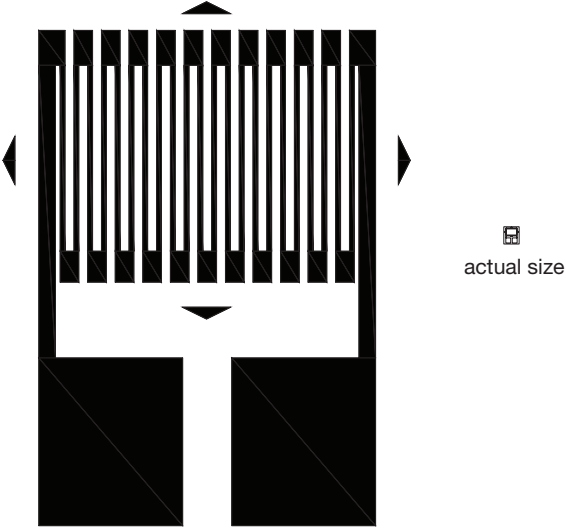

Copper plating for tabs is available.

Transducer-Class® Strain Gages with Advanced Sensors Technology

S5037 GAGE PATTERN DATA			
	<b>GAGE DESIGNATION</b>	<b>RESISTANCE IN OHMS</b>	<b>STD. CREEP CODE</b>
	N2K-XX-S5037Q-10C/DG/E5 N5K-XX-S5037Q-10C/DG/E5	1000 ±0.2% 1000 ±0.2%	Q Q
<b>DESCRIPTION</b> Miniature high resistance pattern.			 <b>RoHS</b> COMPLIANT

GAGE DIMENSIONS						inch	millimeter
Gage Length	Overall Length	Grid Width	Overall Width	Matrix Length	Matrix Width		
0.034	0.087	0.051	0.056	0.09	0.08		
0.86	2.21	1.30	1.42	2.4	1.9		

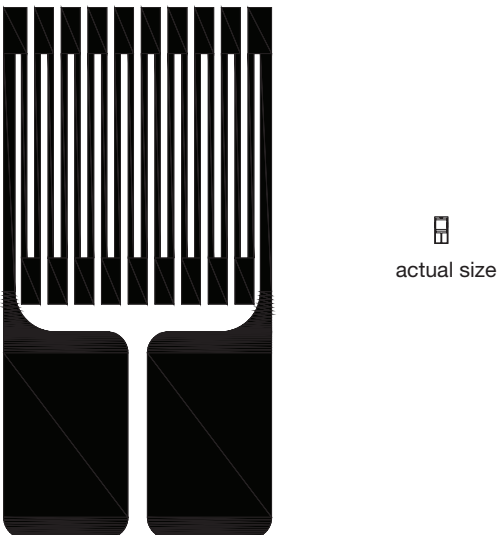

Copper plating for tabs is available.

S5126 GAGE PATTERN DATA			
	<b>GAGE DESIGNATION</b>	<b>RESISTANCE IN OHMS</b>	<b>STD. CREEP CODE</b>
	N2K-XX-S5126S-350/DG/E3 N5K-XX-S5126S-350/DG/E3	350 ±0.2% 350 ±0.2%	S* S*
<b>DESCRIPTION</b> General-purpose miniature pattern.			 <b>RoHS</b> COMPLIANT

GAGE DIMENSIONS						inch	millimeter
Gage Length	Overall Length	Grid Width	Overall Width	Matrix Length	Matrix Width		
0.050	0.131	0.065	0.065	0.14	0.07		
1.27	3.32	1.65	1.65	3.5	1.9		

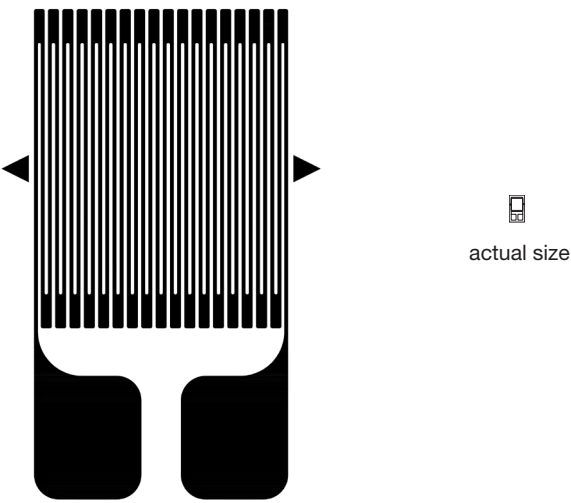

\* Only creep code available for this gage.  
Copper plating for tabs is available.

*Transducer-Class®* Strain Gages with Advanced Sensors Technology

<b>S5262 GAGE PATTERN DATA</b>			
	<b>GAGE DESIGNATION</b>	<b>RESISTANCE IN OHMS</b>	<b>STD. CREEP CODE</b>
	N2A-XX-S5262P-350/E4	350 ±0.15%	P*
<b>DESCRIPTION</b> General-purpose miniature pattern.			

<b>GAGE DIMENSIONS</b>						<b>inch</b>	<b>millimeter</b>
<b>Gage Length</b>	<b>Overall Length</b>	<b>Grid Width</b>	<b>Overall Width</b>	<b>Matrix Length</b>	<b>Matrix Width</b>		
0.062	0.120	0.062	0.062	0.14	0.08		
1.57	3.04	1.57	1.57	3.5	2.1		

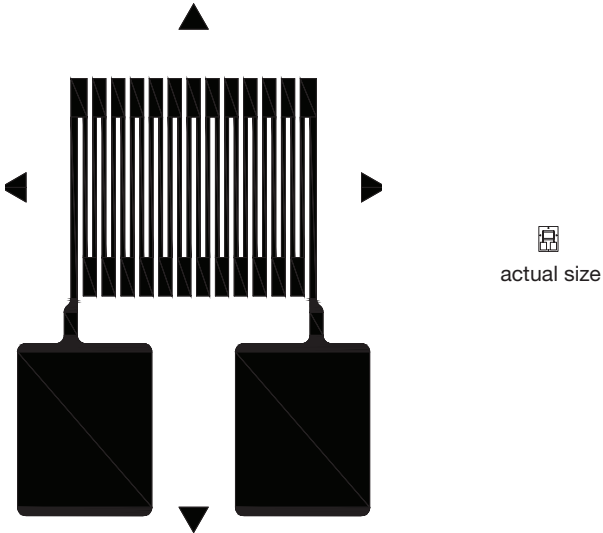

\* Only creep code available for this gage.

<b>S5094 GAGE PATTERN DATA</b>			
	<b>GAGE DESIGNATION</b>	<b>RESISTANCE IN OHMS</b>	<b>STD. CREEP CODE</b>
	N2K-XX-S5094Q-10C/DG/E5 N5K-XX-S5094Q-10C/DG/E5	1000 ±0.2% 1000 ±0.2%	Q* Q*
<b>DESCRIPTION</b> Same grid size as the S5037, with larger solder tabs.			

<b>GAGE DIMENSIONS</b>						<b>inch</b>	<b>millimeter</b>
<b>Gage Length</b>	<b>Overall Length</b>	<b>Grid Width</b>	<b>Overall Width</b>	<b>Matrix Length</b>	<b>Matrix Width</b>		
0.033	0.104	0.054	0.084	0.13	0.10		
0.85	2.64	1.38	2.13	3.4	2.5		

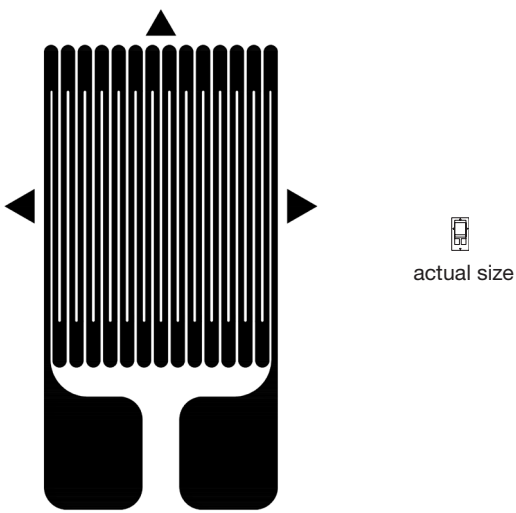

\* Only creep code available for this gage.  
Copper plating for tabs is available.

Transducer-Class® Strain Gages with Advanced Sensors Technology

S5199 GAGE PATTERN DATA			
	<b>GAGE DESIGNATION</b>	<b>RESISTANCE IN OHMS</b>	<b>STD. CREEP CODE</b>
	N2K-XX-S5199T-350/DG/E4 N5K-XX-S5199T-350/DG/E4	350 ±0.15% 350 ±0.15%	T T
<b>DESCRIPTION</b> Narrow version of the S5156.			 <b>RoHS</b> COMPLIANT

GAGE DIMENSIONS						inch	millimeter
Gage Length	Overall Length	Grid Width	Overall Width	Matrix Length	Matrix Width		
0.062	0.124	0.062	0.062	0.17	0.09		
1.57	3.14	1.57	1.57	4.3	2.4		

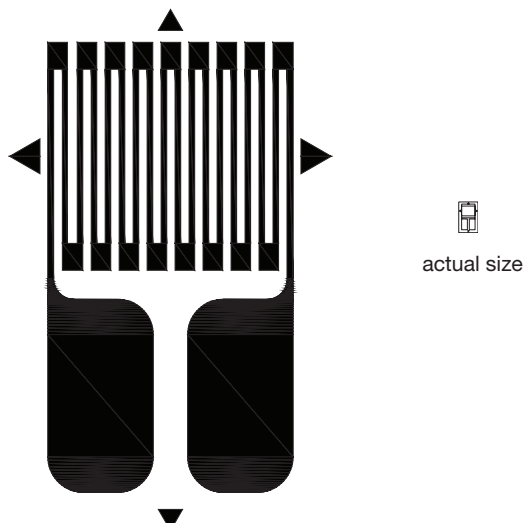

Copper plating for tabs is available.

S5182 GAGE PATTERN DATA			
	<b>GAGE DESIGNATION</b>	<b>RESISTANCE IN OHMS</b>	<b>STD. CREEP CODE</b>
	N2A-XX-S5182N-10C/E4	1000 ±0.2%	N*
<b>DESCRIPTION</b> Miniature high resistance pattern.			 <b>RoHS</b> COMPLIANT

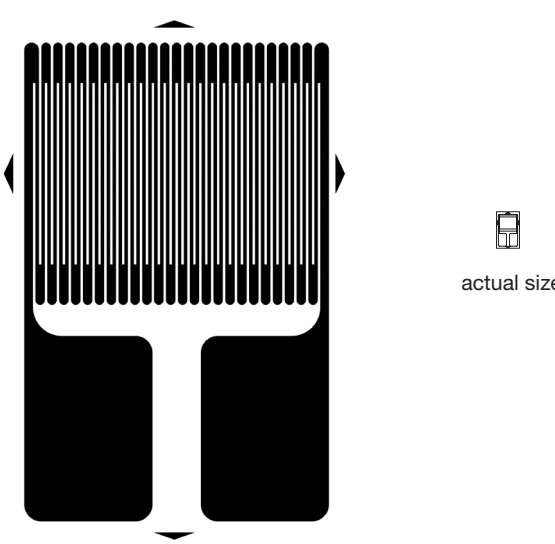

GAGE DIMENSIONS						inch	millimeter
Gage Length	Overall Length	Grid Width	Overall Width	Matrix Length	Matrix Width		
0.050	0.129	0.070	0.070	0.16	0.10		
1.27	3.26	1.78	1.78	4.0	2.5		

\* Only creep code available for this gage.

Transducer-Class® Strain Gages with Advanced Sensors Technology

GAGE PATTERN DATA			
 <p>actual size</p>	<b>GAGE DESIGNATION</b> N2A-XX-S5091R-350/E3 N2A-XX-S5128P-10C/E4	<b>RESISTANCE IN OHMS</b> 350 ±0.2% 1000 ±0.2%	<b>STD. CREEP CODE</b> R P
	<b>DESCRIPTION</b> The most popular small gage pattern.		

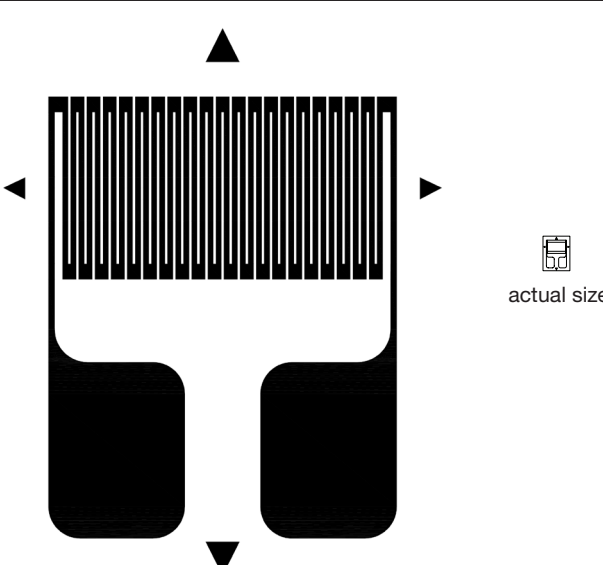

GAGE DIMENSIONS						inch	millimeter
Gage Length	Overall Length	Grid Width	Overall Width	Matrix Length	Matrix Width		
0.060	0.154	0.100	0.100	0.19	0.12		
1.52	3.89	2.54	2.54	4.7	3.0		

S5063 GAGE PATTERN DATA			
 <p>actual size</p>	<b>GAGE DESIGNATION</b> N2K-XX-S5063G-350/DG/E5 N5K-XX-S5063G-350/DG/E5	<b>RESISTANCE IN OHMS</b> 350 ±0.15% 350 ±0.15%	<b>STD. CREEP CODE</b> G* G*
	<b>DESCRIPTION</b> One of the most popular gage sizes.		

GAGE DIMENSIONS						inch	millimeter
Gage Length	Overall Length	Grid Width	Overall Width	Matrix Length	Matrix Width		
0.047	0.137	0.100	0.108	0.18	0.14		
1.19	3.48	2.55	2.75	4.5	3.7		

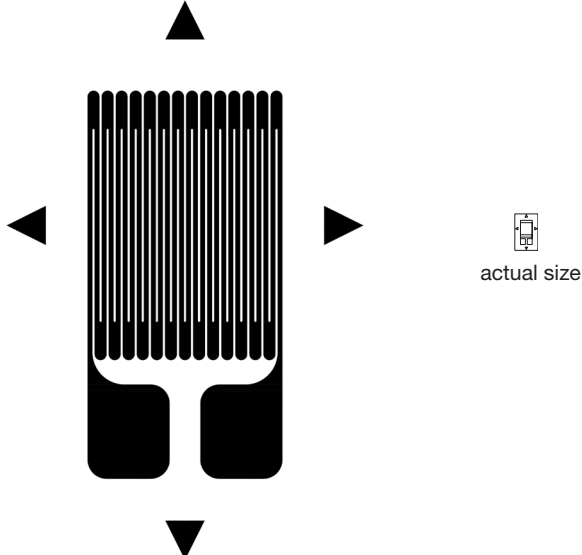

\* Only creep code available for this gage.  
Copper plating for tabs is available.

Transducer-Class® Strain Gages with Advanced Sensors Technology

GAGE PATTERN DATA			
	GAGE DESIGNATION	RESISTANCE IN OHMS	STD. CREEP CODE
	N2A-XX-S5155Q-350/E4	350 ±0.15%	Q*
	N2K-XX-S5156T-350/DG/E4	350 ±0.15%	T*
	N5K-XX-S5156T-350/DG/E4	350 ±0.15%	T*
<b>DESCRIPTION</b> General-purpose miniature patterns.			

GAGE DIMENSIONS					
				inch	millimeter
Gage Length	Overall Length	Grid Width	Overall Width	Matrix Length	Matrix Width
0.062	0.124	0.062	0.062	0.19	0.12
1.57	3.14	1.57	1.57	4.7	3.1

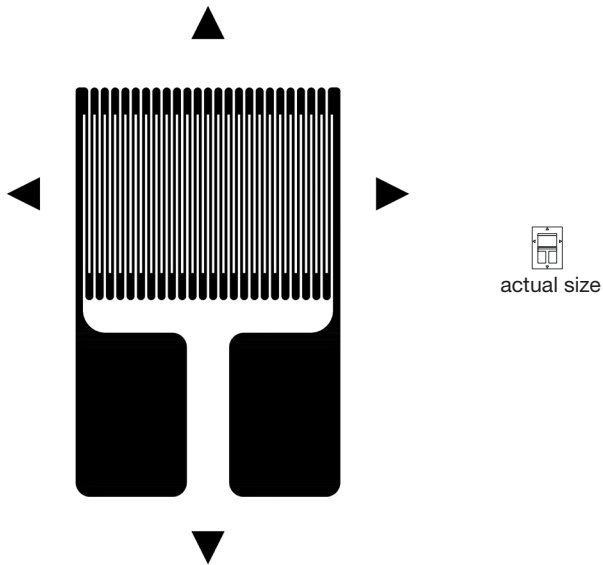

\* Only creep code available for this gage.  
Copper plating for tabs when available.

GAGE PATTERN DATA			
	GAGE DESIGNATION	RESISTANCE IN OHMS	STD. CREEP CODE
	N2K-XX-S5301R-175/DP/E4	175 ±0.15%	R*
	N5K-XX-S5301R-175/DP/E4	175 ±0.15%	R*
	N2A-XX-S5178R-350/E4	350 ±0.2%	R
	N2K-XX-S5114Q-350/DG/E4	350 ±0.2%	Q
	N5K-XX-S5114Q-350/DG/E4	350 ±0.2%	Q
	N2K-XX-S5171Q-10C/DG/E4	1000 ±0.2%	Q*
	N5K-XX-S5171Q-10C/DG/E4	1000 ±0.2%	Q*
<b>DESCRIPTION</b> The most popular small gage pattern.			

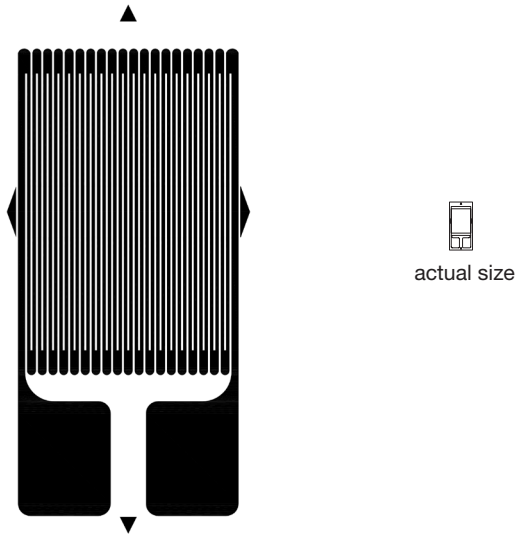

GAGE DIMENSIONS					
				inch	millimeter
Gage Length	Overall Length	Grid Width	Overall Width	Matrix Length	Matrix Width
0.060	0.150	0.100	0.100	0.22	0.16
1.52	3.80	2.54	2.54	5.6	4.1

\* Only creep code available for this gage.  
Copper plating for tabs when applicable.

Transducer-Class® Strain Gages with Advanced Sensors Technology

<b>S5105 GAGE PATTERN DATA</b>			
	<b>GAGE DESIGNATION</b>	<b>RESISTANCE IN OHMS</b>	<b>STD. CREEP CODE</b>
	N2A-XX-S5105R-350/E5	350 ±0.2%	R
<b>DESCRIPTION</b> One of the most popular gage sizes.			 <b>RoHS</b> COMPLIANT

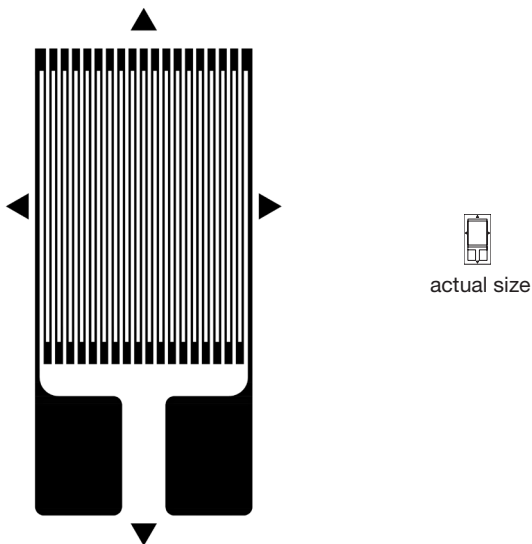
<b>GAGE DIMENSIONS</b>					
				inch	millimeter
<b>Gage Length</b>	<b>Overall Length</b>	<b>Grid Width</b>	<b>Overall Width</b>	<b>Matrix Length</b>	<b>Matrix Width</b>
0.126	0.212	0.100	0.100	0.25	0.12
3.20	5.35	2.54	2.54	6.3	3.0



<b>S5150 GAGE PATTERN DATA</b>			
	<b>GAGE DESIGNATION</b>	<b>RESISTANCE IN OHMS</b>	<b>STD. CREEP CODE</b>
	N2A-XX-S5150R-10C/E4	1000 ±0.2%	R*
<b>DESCRIPTION</b> One of the most popular gage sizes.			 <b>RoHS</b> COMPLIANT

<b>GAGE DIMENSIONS</b>					
				inch	millimeter
<b>Gage Length</b>	<b>Overall Length</b>	<b>Grid Width</b>	<b>Overall Width</b>	<b>Matrix Length</b>	<b>Matrix Width</b>
0.125	0.215	0.100	0.100	0.26	0.14
3.18	5.45	2.54	2.54	6.6	3.5

\* Only creep code available for this gage.



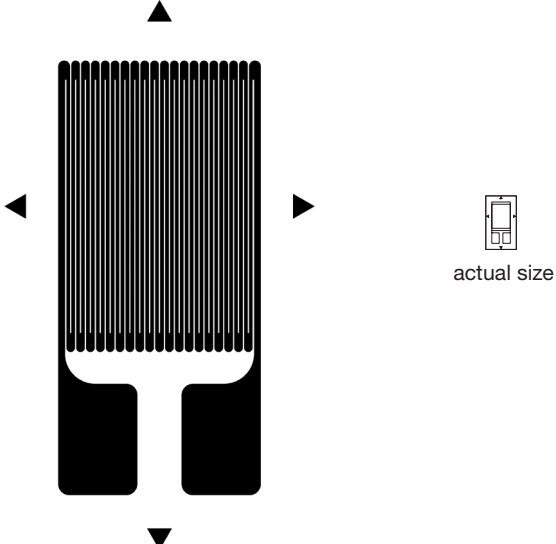

Transducer-Class® Strain Gages with Advanced Sensors Technology

GAGE PATTERN DATA			
 <p>actual size</p>	GAGE DESIGNATION	RESISTANCE IN OHMS	STD. CREEP CODE
	N2A-XX-S5122R-350/E4	350 ±0.15%	R
	N2A-XX-S5286R-120/E5	120 ±0.2%	R*
	N2K-XX-S5109Q-350/DG/E4	350 ±0.2%	Q
	N5K-XX-S5109Q-350/DG/E4	350 ±0.2%	Q
<b>DESCRIPTION</b> One of the most popular gage sizes.			

GAGE DIMENSIONS					
				inch	millimeter
Gage Length	Overall Length	Grid Width	Overall Width	Matrix Length	Matrix Width
0.125	0.215	0.100	0.100	0.28	0.16
3.18	5.45	2.54	2.54	7.1	4.1

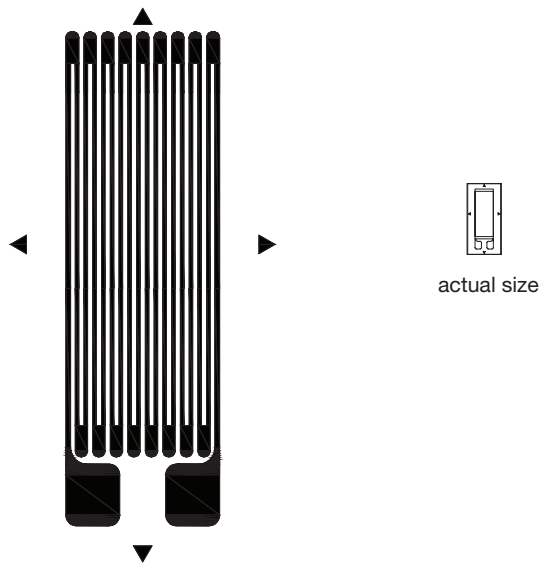

\* Only creep code available for this gage.  
Copper plating for tabs when applicable.

S5148 GAGE PATTERN DATA			
 <p>actual size</p>	GAGE DESIGNATION	RESISTANCE IN OHMS	STD. CREEP CODE
	N2A-XX-S5148X-350/E5	350 ±0.2%	X*
<b>DESCRIPTION</b> Longer grid for strain averaging or where higher power dissipation is required.			

GAGE DIMENSIONS					
				inch	millimeter
Gage Length	Overall Length	Grid Width	Overall Width	Matrix Length	Matrix Width
0.236	0.316	0.100	0.100	0.37	0.18
5.99	8.02	2.54	2.54	9.3	4.6

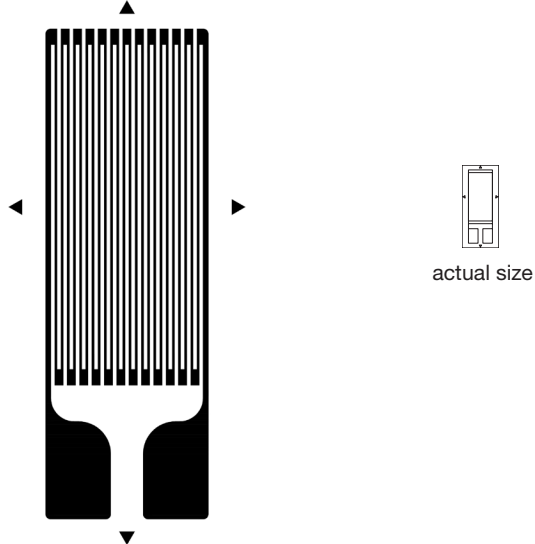

\* Only creep code available for this gage.

*Transducer-Class*® Strain Gages with Advanced Sensors Technology

<b>S5117 GAGE PATTERN DATA</b>			
 <p>actual size</p>	<b>GAGE DESIGNATION</b>	<b>RESISTANCE IN OHMS</b>	<b>STD. CREEP CODE</b>
	N2K-XX-S5117T-10C/DG/E5 N5K-XX-S5117T-10C/DG/E5	1000 ±0.2% 1000 ±0.2%	T* T*
<b>DESCRIPTION</b> Large grid and high resistance permit higher-than-normal excitation voltage.			

<b>GAGE DIMENSIONS</b>					
				inch	millimeter
<b>Gage Length</b>	<b>Overall Length</b>	<b>Grid Width</b>	<b>Overall Width</b>	<b>Matrix Length</b>	<b>Matrix Width</b>
0.250	0.377	0.125	0.125	0.43	0.19
6.35	9.57	3.18	3.18	10.8	4.8

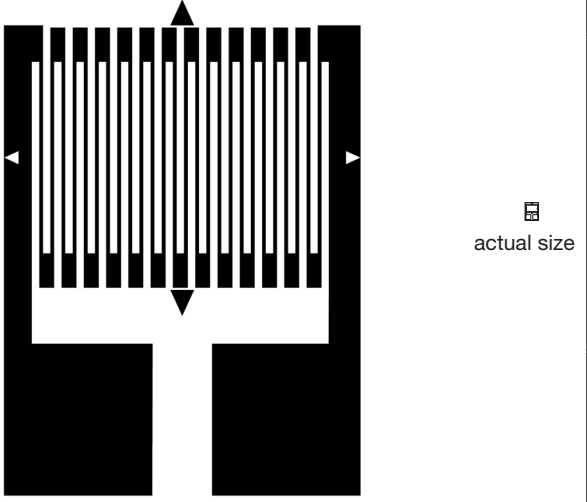

\* Only creep code available for this gage.  
Copper plating for tabs is available.

<b>S5024 GAGE PATTERN DATA</b>			
 <p>actual size</p>	<b>GAGE DESIGNATION</b>	<b>RESISTANCE IN OHMS</b>	<b>STD. CREEP CODE</b>
	N2K-XX-S5024G-50C/DG/E5 N5K-XX-S5024G-50C/DG/E5	5000 ±0.2% 5000 ±0.2%	G G
<b>DESCRIPTION</b> Miniature 5000 Ω linear gage. Can be used in 4 mA to 20 mA transmitters and battery-operated transducers.			

<b>GAGE DIMENSIONS</b>					
				inch	millimeter
<b>Gage Length</b>	<b>Overall Length</b>	<b>Grid Width</b>	<b>Overall Width</b>	<b>Matrix Length</b>	<b>Matrix Width</b>
0.026	0.064	0.048	0.048	0.07	0.06
0.66	1.60	1.22	1.22	1.9	1.4

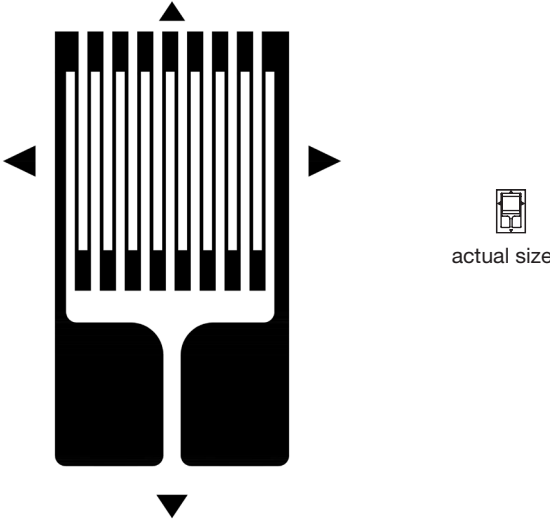

Copper plating for tabs is available.

Transducer-Class® Strain Gages with Advanced Sensors Technology

<b>S5120 GAGE PATTERN DATA</b>			
	<b>GAGE DESIGNATION</b>	<b>RESISTANCE IN OHMS</b>	<b>STD. CREEP CODE</b>
	N2K-XX-S5120S-25C/DG/E5 N5K-XX-S5120S-25C/DG/E5	2500 ±0.2% 2500 ±0.2%	S* S*
<b>DESCRIPTION</b>			 <b>RoHS</b> COMPLIANT
Widely used in 4 mA to 20 mA transmitters and battery-operated transducers.			

<b>GAGE DIMENSIONS</b>					
				inch	millimeter
<b>Gage Length</b>	<b>Overall Length</b>	<b>Grid Width</b>	<b>Overall Width</b>	<b>Matrix Length</b>	<b>Matrix Width</b>
0.050	0.121	0.065	0.070	0.15	0.10
1.27	3.07	1.65	1.78	3.9	2.6

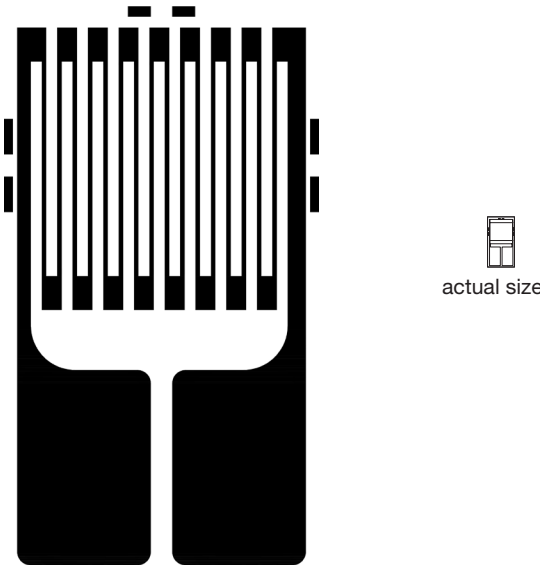

\* Only creep code available for this gage.  
Copper plating for tabs is available.

<b>S5044 GAGE PATTERN DATA</b>			
	<b>GAGE DESIGNATION</b>	<b>RESISTANCE IN OHMS</b>	<b>STD. CREEP CODE</b>
	N2K-XX-S5044Q-50C/DG/E5 N5K-XX-S5044Q-50C/DG/E5	5000 ±0.2% 5000 ±0.2%	Q Q
<b>DESCRIPTION</b>			 <b>RoHS</b> COMPLIANT
Similar grid to S5030 with smaller matrix size. Widely used in 4 mA to 20 mA transmitters and battery-operated transducers.			

<b>GAGE DIMENSIONS</b>					
				inch	millimeter
<b>Gage Length</b>	<b>Overall Length</b>	<b>Grid Width</b>	<b>Overall Width</b>	<b>Matrix Length</b>	<b>Matrix Width</b>
0.129	0.065	0.065	0.14	0.08	0.14
1.27	3.27	1.65	1.65	3.6	1.9

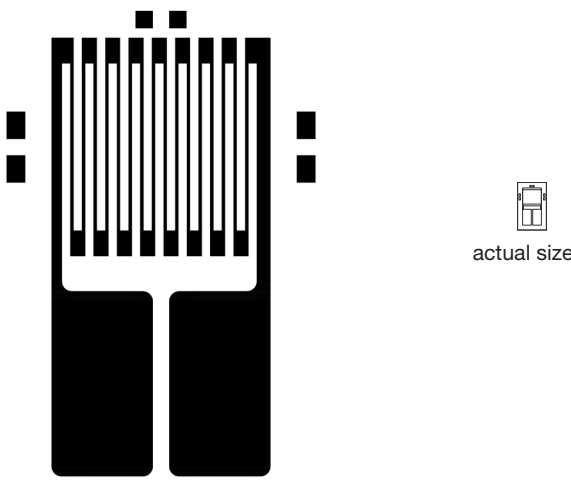

Copper plating for tabs is available.

Transducer-Class® Strain Gages with Advanced Sensors Technology

<b>S5030 GAGE PATTERN DATA</b>			
	<b>GAGE DESIGNATION</b>	<b>RESISTANCE IN OHMS</b>	<b>STD. CREEP CODE</b>
	N2K-XX-S5030K-50C/DG/E5 N5K-XX-S5030K-50C/DG/E5	5000 ±0.2% 5000 ±0.2%	K K
<b>DESCRIPTION</b> Widely used in 4 mA to 20 mA transmitters and battery-operated transducers.			 <b>RoHS</b> COMPLIANT

<b>GAGE DIMENSIONS</b>					
				inch	millimeter
Gage Length	Overall Length	Grid Width	Overall Width	Matrix Length	Matrix Width
0.050	0.129	0.065	0.143	0.14	0.15
1.27	3.27	1.66	3.64	3.6	3.9

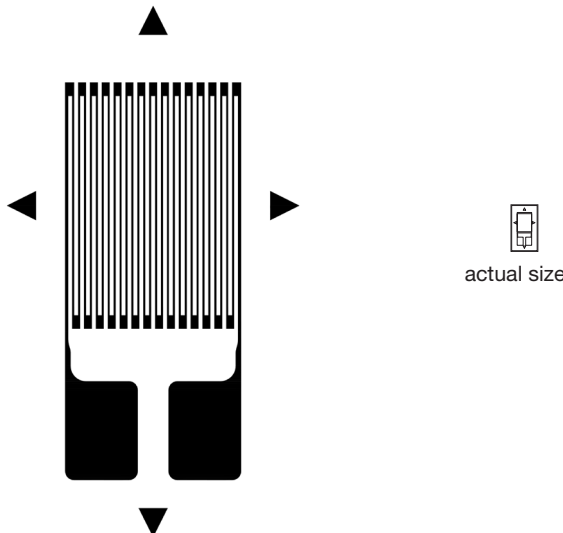

Copper plating for tabs is available.

<b>S5029 GAGE PATTERN DATA</b>			
	<b>GAGE DESIGNATION</b>	<b>RESISTANCE IN OHMS</b>	<b>STD. CREEP CODE</b>
	N2K-XX-S5029L-45C/DG/E5 N5K-XX-S5029L-45C/DG/E5	4500 ±0.2% 4500 ±0.2%	L L
<b>DESCRIPTION</b> Larger grid pattern than the S5030.			 <b>RoHS</b> COMPLIANT

<b>GAGE DIMENSIONS</b>					
				inch	millimeter
Gage Length	Overall Length	Grid Width	Overall Width	Matrix Length	Matrix Width
0.100	0.182	0.080	0.080	0.25	0.14
2.54	4.60	2.03	2.03	6.3	3.5

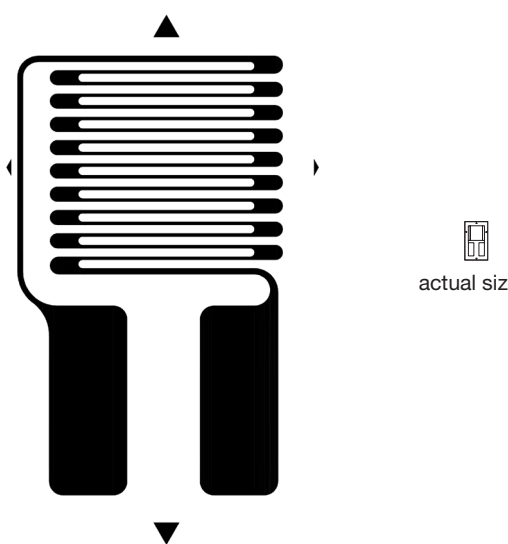

\* Only creep code available for this gage.  
Copper plating for tabs is available.

Transducer-Class® Strain Gages with Advanced Sensors Technology

S5212 GAGE PATTERN DATA			
	<b>GAGE DESIGNATION</b>	<b>RESISTANCE IN OHMS</b>	<b>STD. CREEP CODE</b>
	N2A-XX-S5212R-20C/E5	2000 ±0.2%	R*
<b>DESCRIPTION</b> Constantan pattern, with solder tabs in 90° to grid.			 <b>RoHS COMPLIANT</b>

GAGE DIMENSIONS						inch	millimeter
Gage Length	Overall Length	Grid Width	Overall Width	Matrix Length	Matrix Width		
0.063	0.082	0.075	0.155	0.12	0.20		
1.60	2.08	1.91	3.93	3.0	5.0		

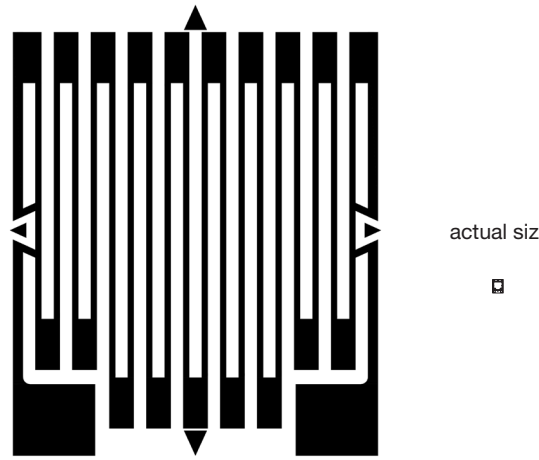

\* Only creep code available for this gage.

S5032 GAGE PATTERN DATA			
	<b>GAGE DESIGNATION</b>	<b>RESISTANCE IN OHMS</b>	<b>STD. CREEP CODE</b>
	N2K-XX-S5032M-100C/DG/E5 N5K-XX-S5032M-100C/DG/E5	10000 ±0.2% 10000 ±0.2%	M M
<b>DESCRIPTION</b> Miniature 10000 Ω linear gage. Can be used in 4 mA to 20 mA transmitters and battery-operated transducers.			 <b>RoHS COMPLIANT</b>

GAGE DIMENSIONS						inch	millimeter
Gage Length	Overall Length	Grid Width	Overall Width	Matrix Length	Matrix Width		
0.040	0.061	0.048	0.048	0.07	0.06		
1.02	1.55	1.22	1.22	1.8	1.4		

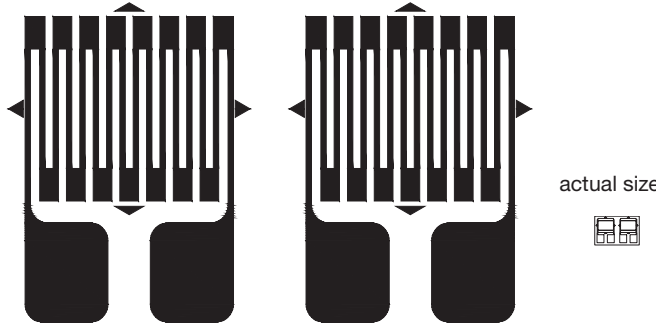

Copper plating for tabs is available.

**Transducer-Class® Strain Gages with Advanced Sensors Technology**

<b>S5100 GAGE PATTERN DATA</b>			
 <p>actual size</p>	<b>GAGE DESIGNATION</b>	<b>RESISTANCE IN OHMS</b>	<b>STD. CREEP CODE</b>
	N2K-XX-S5100Q-10C/DG/E5 N5K-XX-S5100Q-10C/DG/E5	1000 ±0.2% 1000 ±0.2%	Q* Q*
<b>DESCRIPTION</b> Small dual-element gage designed for bending-beam transducers.			

<b>GAGE DIMENSIONS</b>					
				inch	millimeter
<b>Gage Length</b>	<b>Overall Length</b>	<b>Grid Width</b>	<b>Overall Width</b>	<b>Matrix Length</b>	<b>Matrix Width</b>
0.033	0.086	0.054	0.139	0.10	0.15
0.85	2.18	1.38	3.52	2.5	3.9

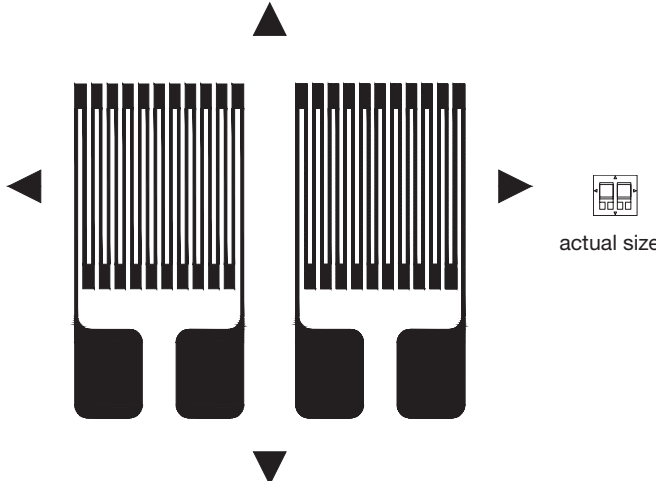

\* Only creep code available for this gage.  
Copper plating for tabs is available.

<b>S5081 GAGE PATTERN DATA</b>			
 <p>actual size</p>	<b>GAGE DESIGNATION</b>	<b>RESISTANCE IN OHMS</b>	<b>STD. CREEP CODE</b>
	N2K-XX-S5081Q-10C/DG/E4 N5K-XX-S5081Q-10C/DG/E4	1000 ±0.2% 1000 ±0.2%	Q* Q*
<b>DESCRIPTION</b> Small dual-element gage designed for bending-beam transducers.			

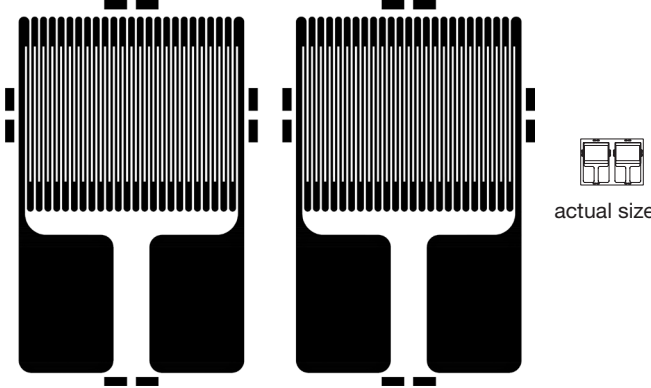

<b>GAGE DIMENSIONS</b>					
				inch	millimeter
<b>Gage Length</b>	<b>Overall Length</b>	<b>Grid Width</b>	<b>Overall Width</b>	<b>Matrix Length</b>	<b>Matrix Width</b>
0.060	0.128	0.065	0.150	0.19	0.21
1.52	3.25	1.65	3.81	4.9	5.3

\* Only creep code available for this gage.  
Copper plating for tabs is available.

Transducer-Class® Strain Gages with Advanced Sensors Technology

GAGE PATTERN DATA			
 <p>actual size</p>	<b>GAGE DESIGNATION</b>	<b>RESISTANCE IN OHMS</b>	<b>STD. CREEP CODE</b>
	N2A-XX-S5092R-350/E4 N2A-XX-S5127P-10C/E4	350 ±0.2% 1000 ±0.2%	R P
<b>DESCRIPTION</b> Small dual-element gage designed for bending-beam transducers.			 <b>RoHS COMPLIANT</b>

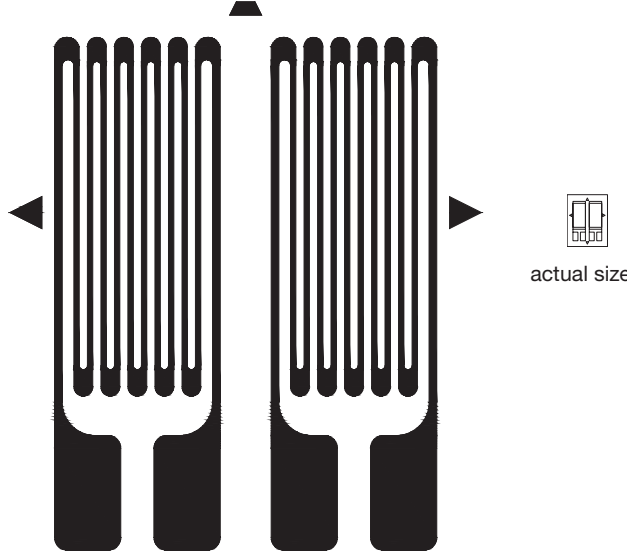
GAGE DIMENSIONS					
				inch	millimeter
<b>Gage Length</b>	<b>Overall Length</b>	<b>Grid Width</b>	<b>Overall Width</b>	<b>Matrix Length</b>	<b>Matrix Width</b>
0.060	0.154	0.100	0.223	0.18	0.24
1.52	3.89	2.54	5.66	4.7	6.2

S5377 GAGE PATTERN DATA			
 <p>actual size</p>	<b>GAGE DESIGNATION</b>	<b>RESISTANCE IN OHMS</b>	<b>STD. CREEP CODE</b>
	N2K-XX-S5377R-350/DG/E4 N5K-XX-S5377R-350/DG/E4	350 ±0.2% 350 ±0.2%	R* R*
<b>DESCRIPTION</b> Dual-element gages widely used on bending-beam transducers.			 <b>RoHS COMPLIANT</b>



GAGE DIMENSIONS					
				inch	millimeter
<b>Gage Length</b>	<b>Overall Length</b>	<b>Grid Width</b>	<b>Overall Width</b>	<b>Matrix Length</b>	<b>Matrix Width</b>
0.125	0.195	0.065	0.150	0.27	0.21
3.18	4.96	1.65	3.81	6.9	5.3

\* Only creep code available for this gage.  
Copper plating for tabs is available.



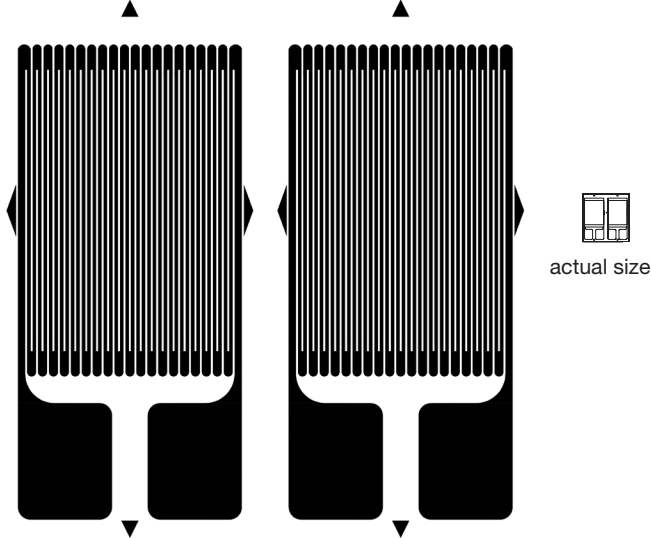

Transducer-Class® Strain Gages with Advanced Sensors Technology

**S5119 GAGE PATTERN DATA**

 <p>actual size</p>	<p><b>GAGE DESIGNATION</b></p> <p>N2A-XX-S5119R-350/E4</p>	<p><b>RESISTANCE IN OHMS</b></p> <p>350 ±0.2%</p>	<p><b>STD. CREEP CODE</b></p> <p>R</p>
	<p><b>DESCRIPTION</b></p> <p>Dual-element gages widely used on bending-beam transducers.</p>		

GAGE DIMENSIONS						inch	millimeter
Gage Length	Overall Length	Grid Width	Overall Width	Matrix Length	Matrix Width		
0.126	0.224	0.100	0.221	0.25	0.24		
3.20	5.68	2.54	5.61	6.3	6.1		

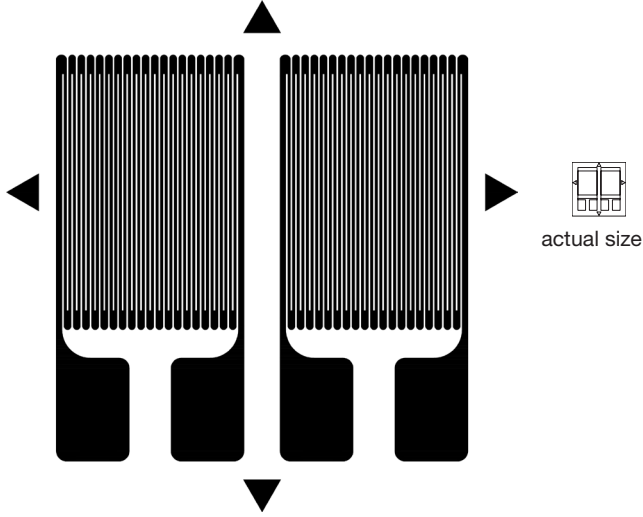

**S5167 GAGE PATTERN DATA**

 <p>actual size</p>	<p><b>GAGE DESIGNATION</b></p> <p>N2A-XX-S5167R-350/E4</p>	<p><b>RESISTANCE IN OHMS</b></p> <p>350 ±0.2%</p>	<p><b>STD. CREEP CODE</b></p> <p>R*</p>
	<p><b>DESCRIPTION</b></p> <p>Dual-element gages widely used on bending-beam transducers.</p>		

GAGE DIMENSIONS						inch	millimeter
Gage Length	Overall Length	Grid Width	Overall Width	Matrix Length	Matrix Width		
0.125	0.215	0.100	0.220	0.28	0.28		
3.18	5.46	2.54	5.59	7.1	7.1		

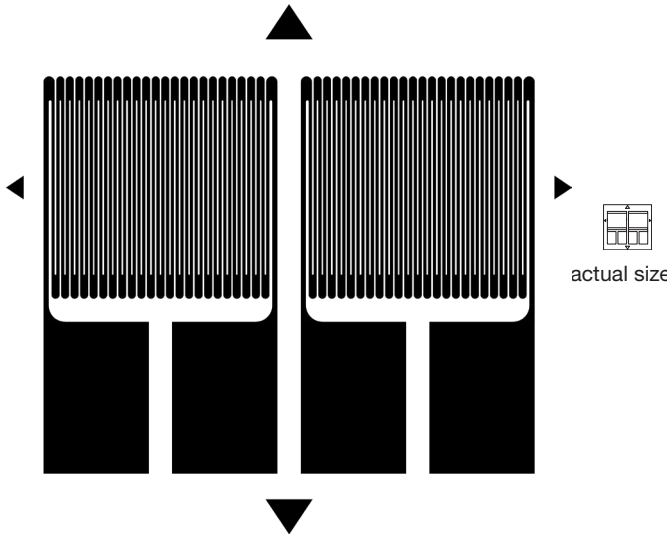

\* Only creep code available for this gage.

Transducer-Class® Strain Gages with Advanced Sensors Technology

S5249 GAGE PATTERN DATA						
				<b>GAGE DESIGNATION</b>	<b>RESISTANCE IN OHMS</b>	<b>STD. CREEP CODE</b>
				N2K-XX-S5249R-10C/DG/E5 N5K-XX-S5249R-10C/DG/E5	1000 ±0.2% 1000 ±0.2%	R* R*
<b>DESCRIPTION</b> Small dual-element gage designed for bending-beam transducers.						

GAGE DIMENSIONS						inch	millimeter
Gage Length	Overall Length	Grid Width	Overall Width	Matrix Length	Matrix Width		
0.075	0.170	0.100	0.210	0.24	0.25		
1.90	4.31	2.54	5.33	6.0	6.4		

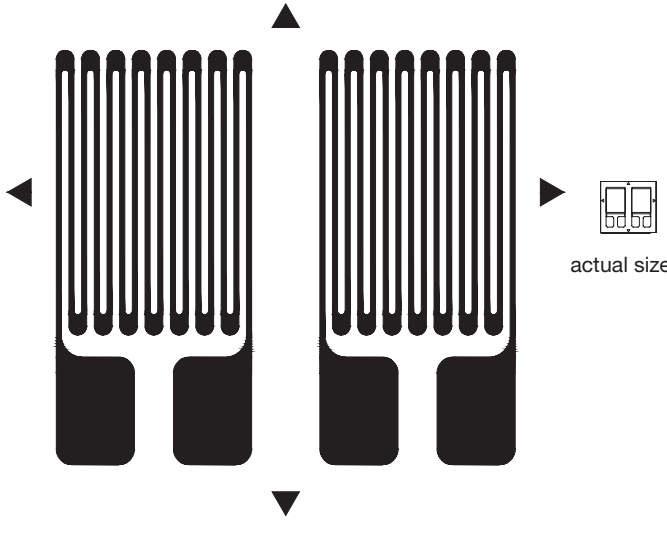

\* Only creep code available for this gage.  
Copper plating for tabs is available.

GAGE PATTERN DATA						
				<b>GAGE DESIGNATION</b>	<b>RESISTANCE IN OHMS</b>	<b>STD. CREEP CODE</b>
				N2A-XX-S5348R-700/E5 N2A-XX-S5258R-10C/E5	700 ±0.2% 1000 ±0.2%	R* R*
<b>DESCRIPTION</b> Dual-element gages widely used on bending-beam transducers.						

GAGE DIMENSIONS						inch	millimeter
Gage Length	Overall Length	Grid Width	Overall Width	Matrix Length	Matrix Width		
0.125	0.212	0.100	0.235	0.27	0.29		
3.18	5.39	2.54	5.99	6.9	7.4		

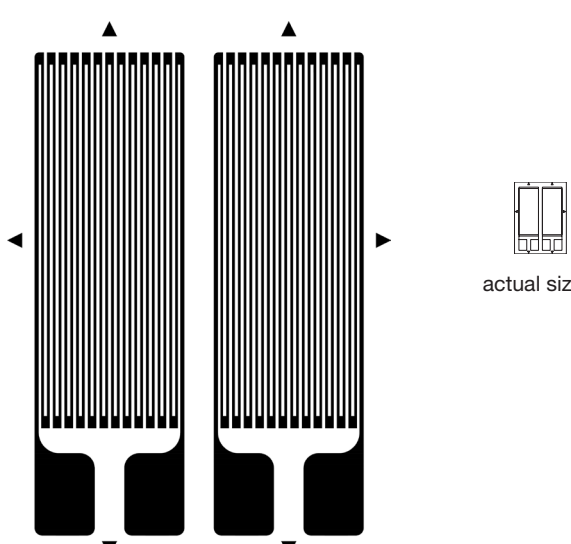

\* Only creep code available for this gage.

*Transducer-Class®* Strain Gages with Advanced Sensors Technology

<b>S5083 GAGE PATTERN DATA</b>			
 <p>actual size</p>	<b>GAGE DESIGNATION</b> N2K-XX-S5083P-10C/DG/E5 N5K-XX-S5083P-10C/DG/E5	<b>RESISTANCE IN OHMS</b> 1000 ±0.2% 1000 ±0.2%	<b>STD. CREEP CODE</b> P P
	<b>DESCRIPTION</b> Widely used on bending-beam transducers where greater power dissipation is required.		 <b>RoHS COMPLIANT</b>

<b>GAGE DIMENSIONS</b>						inch	millimeter
Gage Length	Overall Length	Grid Width	Overall Width	Matrix Length	Matrix Width		
0.236	0.324	0.100	0.220	0.37	0.27		
5.99	8.22	2.54	5.59	9.3	6.7		

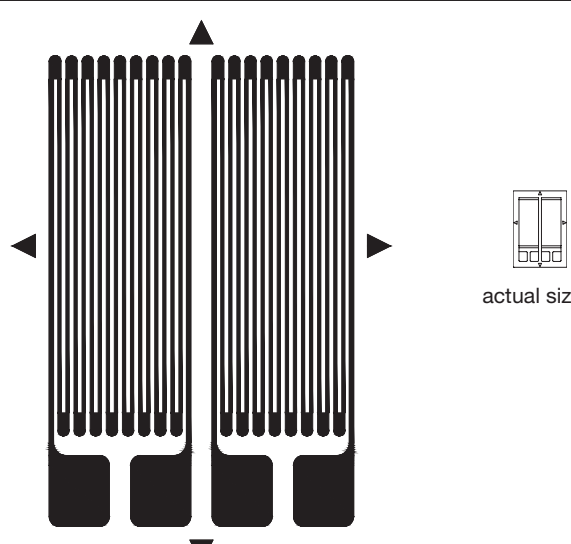

Copper plating for tabs is available.

<b>S5277 GAGE PATTERN DATA</b>			
 <p>actual size</p>	<b>GAGE DESIGNATION</b> N2A-XX-S5277X-350/E5	<b>RESISTANCE IN OHMS</b> 350 ±0.2%	<b>STD. CREEP CODE</b> X*
	<b>DESCRIPTION</b> Widely used on bending-beam transducers where greater power dissipation is required.		 <b>RoHS COMPLIANT</b>

<b>GAGE DIMENSIONS</b>						inch	millimeter
Gage Length	Overall Length	Grid Width	Overall Width	Matrix Length	Matrix Width		
0.236	0.331	0.100	0.215	0.39	0.28		
5.99	8.40	2.54	5.47	9.9	7.0		

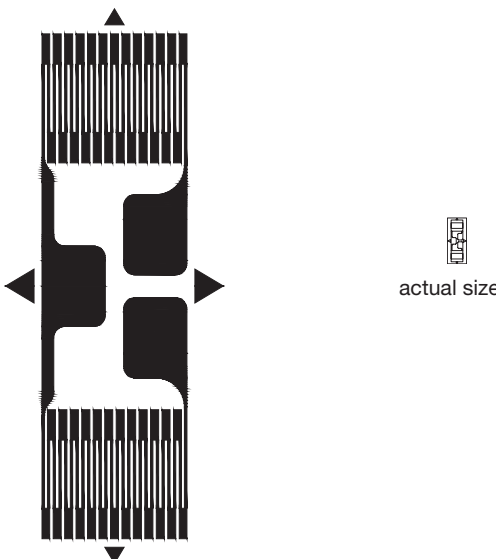

\* Only creep code available for this gage.

Transducer-Class® Strain Gages with Advanced Sensors Technology

<b>S5375 GAGE PATTERN DATA</b>			
	<b>GAGE DESIGNATION</b>	<b>RESISTANCE IN OHMS</b>	<b>STD. CREEP CODE</b>
	N2K-XX-S5375U-350/DG/E4 N5K-XX-S5375U-350/DG/E4	350 ±0.2% 350 ±0.2%	U* U*
<b>DESCRIPTION</b> Half-bridge common-tab pattern. Grid centerline spacing 0.164 in (4.17 mm).			

<b>GAGE DIMENSIONS</b>					
				inch	millimeter
Gage Length	Overall Length	Grid Width	Overall Width	Matrix Length	Matrix Width
0.030	0.194	0.063	0.063	0.25	0.10
0.76	4.93	1.60	1.60	6.4	2.6

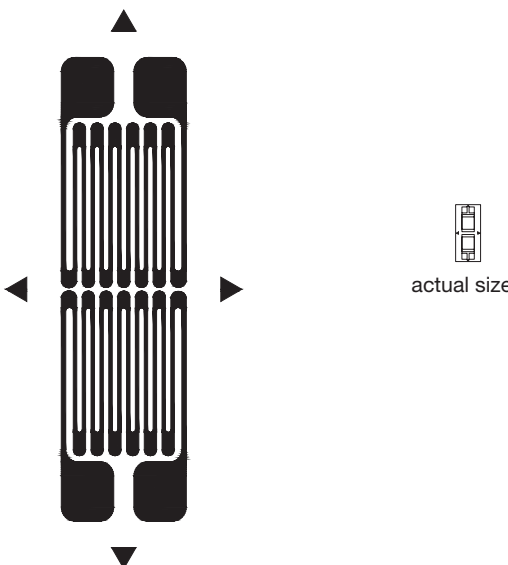

\* Only creep code available for this gage.  
Copper plating for tabs is available.

<b>S5333 GAGE PATTERN DATA</b>			
	<b>GAGE DESIGNATION</b>	<b>RESISTANCE IN OHMS</b>	<b>STD. CREEP CODE</b>
	N2K-XX-S5333P-350/DG/E4 N5K-XX-S5333P-350/DG/E4	350 ±0.2% 350 ±0.2%	P* P*
<b>DESCRIPTION</b> Dual-element pattern for narrow bending beams. Grid centerline spacing 0.080 in (2.03mm)			

<b>GAGE DIMENSIONS</b>					
				inch	millimeter
Gage Length	Overall Length	Grid Width	Overall Width	Matrix Length	Matrix Width
0.062	0.230	0.062	0.062	0.29	0.13
1.57	5.84	1.57	1.57	7.3	3.2

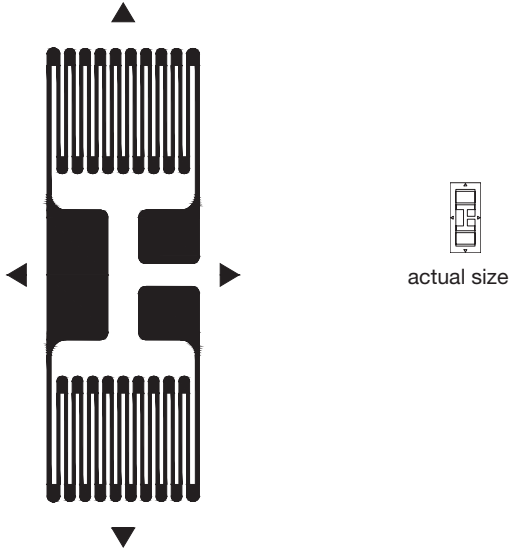

\* Only creep code available for this gage.  
Copper plating for tabs is available.

Transducer-Class® Strain Gages with Advanced Sensors Technology

<b>S5266 GAGE PATTERN DATA</b>			
 <p>actual size</p>	<b>GAGE DESIGNATION</b>	<b>RESISTANCE IN OHMS</b>	<b>STD. CREEP CODE</b>
	N2A-XX-S5266R-350/E5	350 ±0.2%	R*
<b>DESCRIPTION</b> Half-bridge common-tab pattern. Grid centerline spacing 0.215 in (5.46 mm).			

<b>GAGE DIMENSIONS</b>					
				inch	millimeter
Gage Length	Overall Length	Grid Width	Overall Width	Matrix Length	Matrix Width
0.060	0.285	0.100	0.100	0.36	0.16
1.52	7.24	2.54	2.54	9.3	4.1

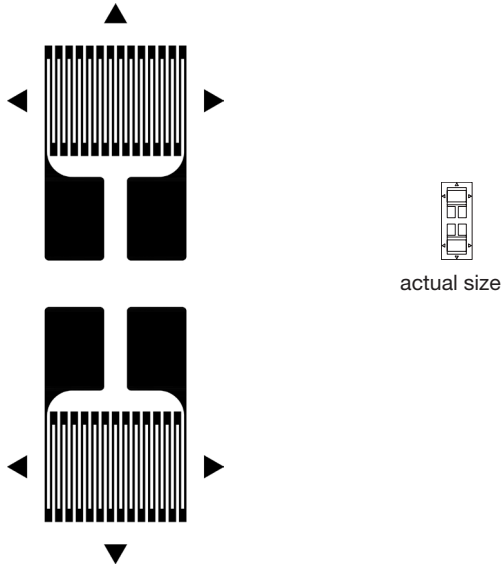

\* Only creep code available for this gage.

<b>S5269 GAGE PATTERN DATA</b>			
 <p>actual size</p>	<b>GAGE DESIGNATION</b>	<b>RESISTANCE IN OHMS</b>	<b>STD. CREEP CODE</b>
	N2K-XX-S5269Q-350/DG/E5 N5K-XX-S5269Q-350/DG/E5	350 ±0.2% 350 ±0.2%	Q* Q*
<b>DESCRIPTION</b> Dual-element pattern for bending beams.			

<b>GAGE DIMENSIONS</b>					
				inch	millimeter
Gage Length	Overall Length	Grid Width	Overall Width	Matrix Length	Matrix Width
0.060	0.328	0.100	0.100	0.41	0.16
1.52	8.33	2.54	2.54	10.3	4.1

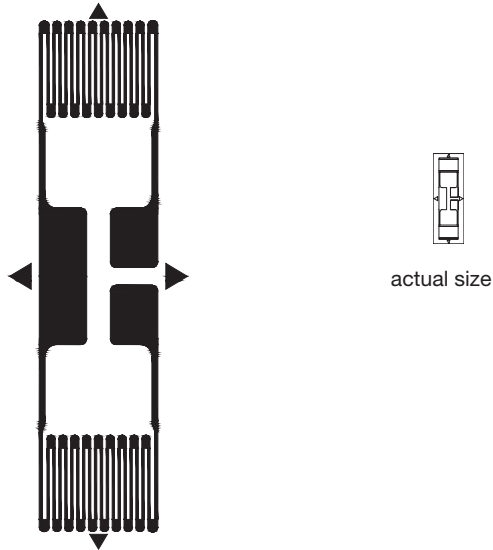

\* Only creep code available for this gage.  
Copper plating for tabs is available.

Transducer-Class® Strain Gages with Advanced Sensors Technology

S5297 GAGE PATTERN DATA			
	<b>GAGE DESIGNATION</b>	<b>RESISTANCE IN OHMS</b>	<b>STD. CREEP CODE</b>
	N2A-XX-S5297R-350/E5	350 ±0.2%	R*
<b>DESCRIPTION</b> Half-bridge common-tab pattern. Grid centerline spacing 0.350 in (8.89 mm).			

GAGE DIMENSIONS					
				inch	millimeter
Gage Length	Overall Length	Grid Width	Overall Width	Matrix Length	Matrix Width
0.060	0.420	0.100	0.100	0.47	0.16
1.52	10.67	2.54	2.54	12.0	4.1

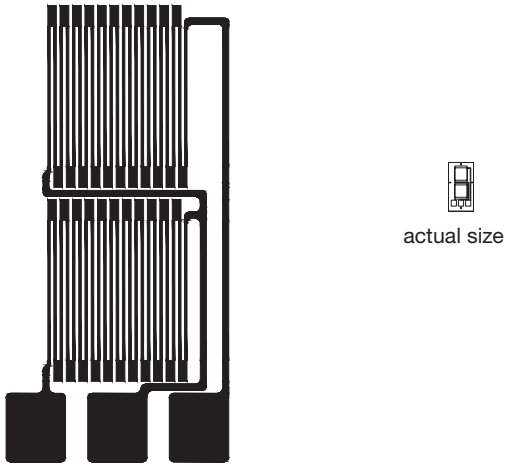
\* Only creep code available for this gage.



S5070 GAGE PATTERN DATA			
	<b>GAGE DESIGNATION</b>	<b>RESISTANCE IN OHMS</b>	<b>STD. CREEP CODE</b>
	N2K-XX-S5070Q-20C/DG/E3 N5K-XX-S5070Q-20C/DG/E3	2000 ±0.2% 2000 ±0.2%	Q* Q*
<b>DESCRIPTION</b> Half-bridge common-tab pattern.			

GAGE DIMENSIONS					
Gage Length	Overall Length	Grid Width	Overall Width	Matrix Length	Matrix Width
0.062	0.201	0.062	0.098	0.25	0.13
1.58	5.11	1.58	2.49	6.3	3.2

\* Only creep code available for this gage.  
Copper plating for tabs is available.

Transducer-Class® Strain Gages with Advanced Sensors Technology

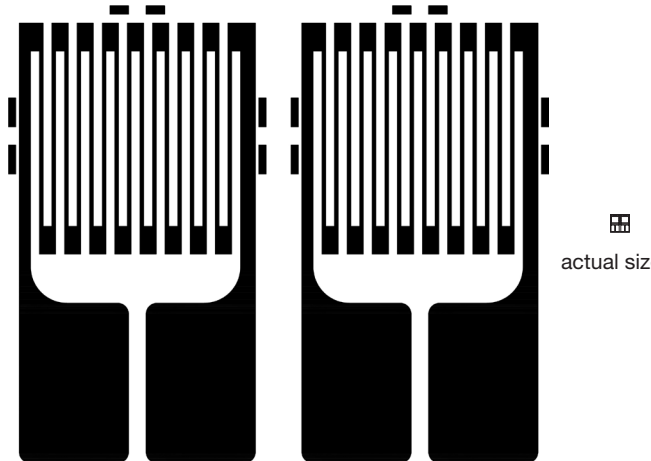
**S5280 GAGE PATTERN DATA**



	<p><b>GAGE DESIGNATION</b></p> <p>N2K-XX-S5280Q-50C/DG/E3 N5K-XX-S5280Q-50C/DG/E3</p>	<p><b>RESISTANCE IN OHMS</b></p> <p>5000 ±0.2% 5000 ±0.2%</p>	<p><b>STD. CREEP CODE</b></p> <p>Q* Q*</p>
	<p><b>DESCRIPTION</b></p> <p>Dual linear S5044 gage side by side.</p>		 <p><b>RoHS COMPLIANT</b></p>

**GAGE DIMENSIONS**

				inch	millimeter
Gage Length	Overall Length	Grid Width	Overall Width	Matrix Length	Matrix Width
0.050	0.129	0.065	0.065	0.17	0.10
1.27	3.27	1.65	1.65	4.2	2.5

\* Only creep code available for this gage.  
Copper plating for tabs is available.

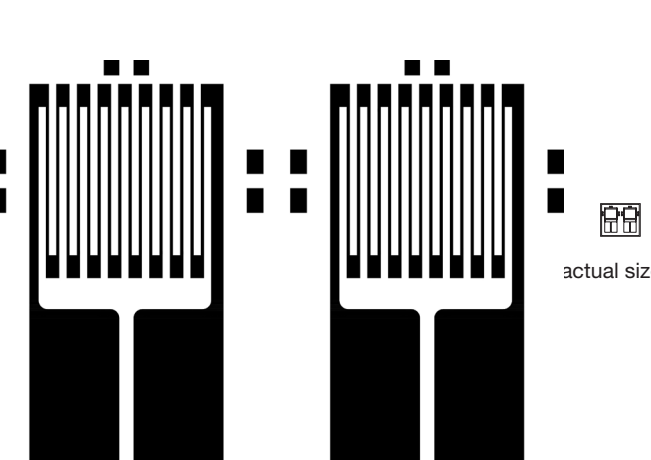
**S5054 GAGE PATTERN DATA**

	<p><b>GAGE DESIGNATION</b></p> <p>N2K-XX-S5054K-50C/DG/E5 N5K-XX-S5054K-50C/DG/E5</p>	<p><b>RESISTANCE IN OHMS</b></p> <p>5000 ±0.2% 5000 ±0.2%</p>	<p><b>STD. CREEP CODE</b></p> <p>K* K*</p>
	<p><b>DESCRIPTION</b></p> <p>Small full bridge for bending-beam transducers. Bridge is balanced to ±0.4 mV/V, but RG is 1000 Ω ±3%.</p>		 <p><b>RoHS COMPLIANT</b></p>



**GAGE DIMENSIONS**

				inch	millimeter
Gage Length	Overall Length	Grid Width	Overall Width	Matrix Length	Matrix Width
0.050	0.129	0.065	0.166	0.17	0.20
1.27	3.27	1.65	4.22	4.2	5.1

\* Only creep code available for this gage.  
Copper plating for tabs is available.



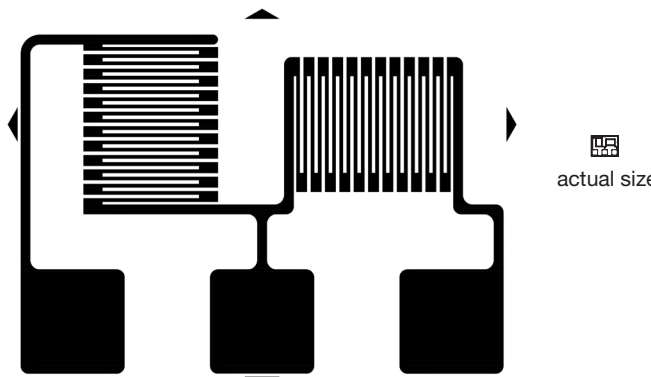

**Transducer-Class® Strain Gages with Advanced Sensors Technology**

GAGE PATTERN DATA			
	GAGE DESIGNATION	RESISTANCE IN OHMS	STD. CREEP CODE
	N2A-XX-S5209K-175/E5	175 ±0.2%	K*
	N2K-XX-S5038P-10C/DG/E3	1000 ±0.2%	P
	N5K-XX-S5038P-10C/DG/E3	1000 ±0.2%	P
	N2K-XX-S5039H-50C/DG/E5	5000 ±0.3%	H*
	N5K-XX-S5039H-50C/DG/E5	5000 ±0.3%	H*
<b>DESCRIPTION</b> Encapsulated 90° tee rosette.			 <b>RoHS</b> COMPLIANT

GAGE DIMENSIONS					
				inch	millimeter
Gage Length	Overall Length	Grid Width	Overall Width	Matrix Length	Matrix Width
0.033	0.092	0.051	0.130	0.10	0.14
0.83	2.34	1.30	3.30	2.7	3.6

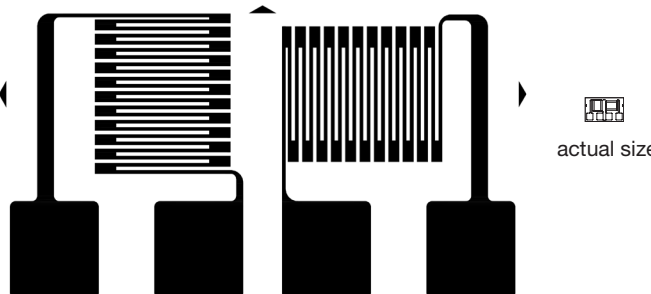

\* Only creep code available for this gage.  
Copper plating for tabs when applicable.

GAGE PATTERN DATA			
	GAGE DESIGNATION	RESISTANCE IN OHMS	STD. CREEP CODE
	N2K-XX-S5096Q-10C/DG/E3	1000 ±0.2%	Q*
	N5K-XX-S5096Q-10C/DG/E3	1000 ±0.2%	Q*
	N2K-XX-S5101M-50C/DG/E3	5000 ±0.2%	M*
	N5K-XX-S5101M-50C/DG/E3	5000 ±0.2%	M*
<b>DESCRIPTION</b> General-purpose 90° tee rosette.			 <b>RoHS</b> COMPLIANT

GAGE DIMENSIONS					
				inch	millimeter
Gage Length	Overall Length	Grid Width	Overall Width	Matrix Length	Matrix Width
0.034	0.102	0.055	0.182	0.12	0.20
0.85	2.59	1.41	4.62	3.1	5.0

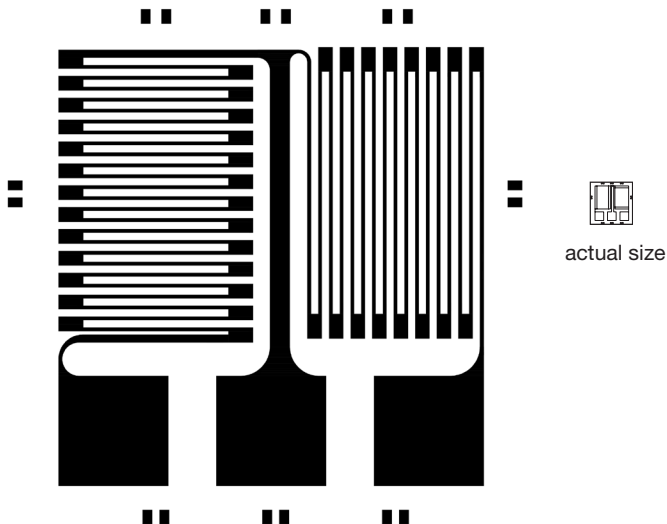

\* Only creep code available for this gage.  
Copper plating for tabs is available.

Transducer-Class® Strain Gages with Advanced Sensors Technology

GAGE PATTERN DATA			
 <p>actual size</p>	<b>GAGE DESIGNATION</b> N2A-XX-S5189R-175/E5 N2A-XX-S5161R-350/E5	<b>RESISTANCE IN OHMS</b> 175 ±0.2% 350 ±0.2%	<b>STD. CREEP CODE</b> R* R*
	<b>DESCRIPTION</b> Designed for half-bridge transducers.		 <b>RoHS COMPLIANT</b>

GAGE DIMENSIONS					
				inch	millimeter
<b>Gage Length</b>	<b>Overall Length</b>	<b>Grid Width</b>	<b>Overall Width</b>	<b>Matrix Length</b>	<b>Matrix Width</b>
0.100	0.175	0.120	0.175	0.22	0.22
2.54	4.44	3.00	4.44	5.6	5.6

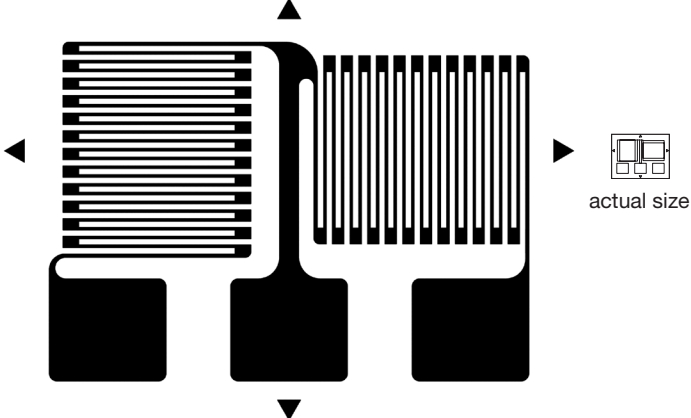

\* Only creep code available for this gage.

GAGE PATTERN DATA			
 <p>actual size</p>	<b>GAGE DESIGNATION</b> N2A-XX-S5129N-350/E4 N2A-XX-S5152P-10C/E4	<b>RESISTANCE IN OHMS</b> 350 ±0.2% 1000 ±0.2%	<b>STD. CREEP CODE</b> N P
	<b>DESCRIPTION</b> General-purpose, three-tab 90° tee rosette.		 <b>RoHS COMPLIANT</b>

GAGE DIMENSIONS					
				inch	millimeter
<b>Gage Length</b>	<b>Overall Length</b>	<b>Grid Width</b>	<b>Overall Width</b>	<b>Matrix Length</b>	<b>Matrix Width</b>
0.080	0.165	0.110	0.246	0.23	0.30
2.03	4.20	2.79	6.25	5.8	7.6

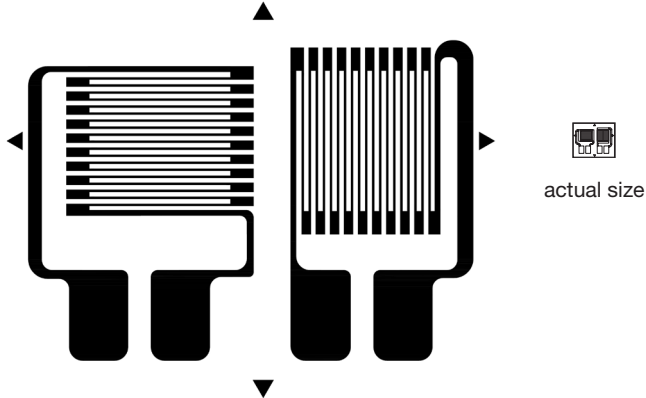

\* Only creep code available for this gage.

Transducer-Class® Strain Gages with Advanced Sensors Technology

S5195 GAGE PATTERN DATA			
	<b>GAGE DESIGNATION</b>	<b>RESISTANCE IN OHMS</b>	<b>STD. CREEP CODE</b>
	N2A-XX-S5195R-350/E5	350 ±0.2%	R*
<b>DESCRIPTION</b> General-purpose, four-tab 90° tee rosette.			

GAGE DIMENSIONS					
				inch	millimeter
<b>Gage Length</b>	<b>Overall Length</b>	<b>Grid Width</b>	<b>Overall Width</b>	<b>Matrix Length</b>	<b>Matrix Width</b>
0.062	0.137	0.062	0.160	0.18	0.22
1.57	3.48	1.57	4.07	4.6	5.6

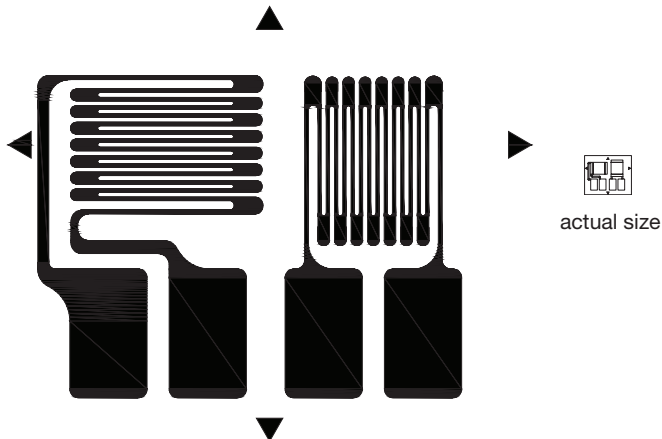

\* Only creep code available for this gage.

S5190 GAGE PATTERN DATA			
	<b>GAGE DESIGNATION</b>	<b>RESISTANCE IN OHMS</b>	<b>STD. CREEP CODE</b>
	N2K-XX-S5190T-350/DP/E5 N5K-XX-S5190T-350/DP/E5	350 ±0.2% 350 ±0.2%	T* T*
<b>DESCRIPTION</b> General-purpose, four-tab 90° tee rosette.			

GAGE DIMENSIONS					
				inch	millimeter
<b>Gage Length</b>	<b>Overall Length</b>	<b>Grid Width</b>	<b>Overall Width</b>	<b>Matrix Length</b>	<b>Matrix Width</b>
0.062	0.157	0.062	0.178	0.20	0.25
1.57	3.98	1.57	4.51	5.2	6.2

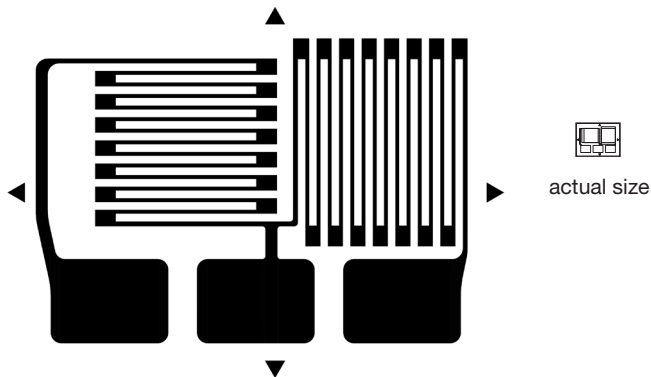

\* Only creep code available for this gage.  
Copper plating for tabs is available.

Transducer-Class® Strain Gages with Advanced Sensors Technology

S5115 GAGE PATTERN DATA			
	<b>GAGE DESIGNATION</b>	<b>RESISTANCE IN OHMS</b>	<b>STD. CREEP CODE</b>
	N2K-XX-S5115T-350/DG/E3 N5K-XX-S5115T-350/DG/E3	350 ±0.2% 350 ±0.2%	T* T*
<b>DESCRIPTION</b> General-purpose, three-tab 90° tee rosette.			

GAGE DIMENSIONS					
				inch	millimeter
<b>Gage Length</b>	<b>Overall Length</b>	<b>Grid Width</b>	<b>Overall Width</b>	<b>Matrix Length</b>	<b>Matrix Width</b>
0.100	0.245	0.100	0.170	0.31	0.23
2.54	6.22	2.54	4.32	7.7	5.8

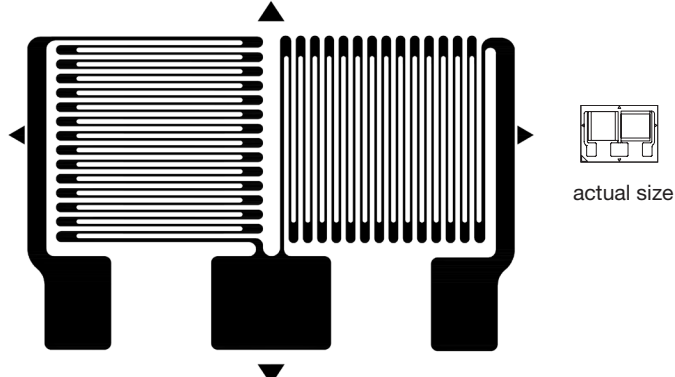

\* Only creep code available for this gage.  
Copper plating for tabs is available.

S5255 GAGE PATTERN DATA			
	<b>GAGE DESIGNATION</b>	<b>RESISTANCE IN OHMS</b>	<b>STD. CREEP CODE</b>
	N2A-XX-S5255W-350/E5	350 ±0.2%	W*
<b>DESCRIPTION</b> General-purpose, three-tab 90° tee rosette.			

GAGE DIMENSIONS					
				inch	millimeter
<b>Gage Length</b>	<b>Overall Length</b>	<b>Grid Width</b>	<b>Overall Width</b>	<b>Matrix Length</b>	<b>Matrix Width</b>
0.125	0.235	0.150	0.340	0.30	0.40
3.18	5.97	3.81	8.64	7.5	10.2

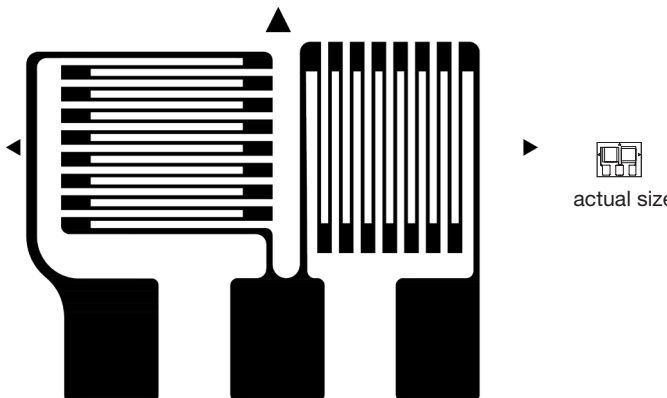

\* Only creep code available for this gage.

Transducer-Class® Strain Gages with Advanced Sensors Technology

S5284 GAGE PATTERN DATA			
	<b>GAGE DESIGNATION</b>	<b>RESISTANCE IN OHMS</b>	<b>STD. CREEP CODE</b>
	N2A-XX-S5284T-10C/E5	1000 ±0.2%	T*
<b>DESCRIPTION</b> General-purpose, three-tab 90° tee rosette.			 <b>RoHS COMPLIANT</b>

GAGE DIMENSIONS					
				inch	millimeter
<b>Gage Length</b>	<b>Overall Length</b>	<b>Grid Width</b>	<b>Overall Width</b>	<b>Matrix Length</b>	<b>Matrix Width</b>
0.063	0.149	0.075	0.182	0.18	0.23
1.60	3.78	1.91	4.62	4.5	5.8

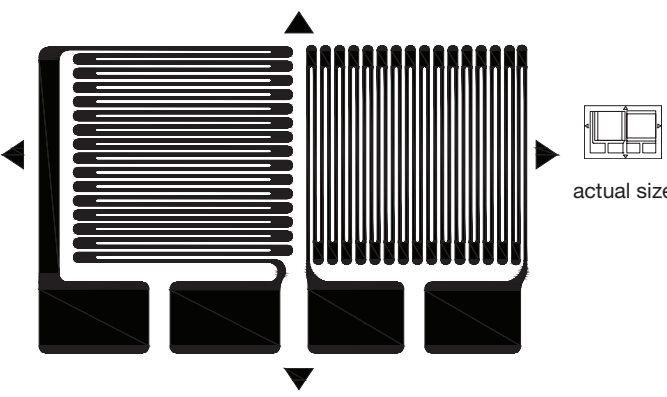

\* Only creep code available for this gage.

S5302 GAGE PATTERN DATA			
	<b>GAGE DESIGNATION</b>	<b>RESISTANCE IN OHMS</b>	<b>STD. CREEP CODE</b>
	N2A-XX-S5302W-350/E5 N2A-XX-S5302W-350/E5	350 ±0.2% 350 ±0.2%	W* W*
<b>DESCRIPTION</b> General-purpose, four-tab 90° tee rosette.			 <b>RoHS COMPLIANT</b>

GAGE DIMENSIONS					
				inch	millimeter
<b>Gage Length</b>	<b>Overall Length</b>	<b>Grid Width</b>	<b>Overall Width</b>	<b>Matrix Length</b>	<b>Matrix Width</b>
0.125	0.218	0.150	0.340	0.28	0.40
3.18	5.53	3.81	8.64	7.00	10.2

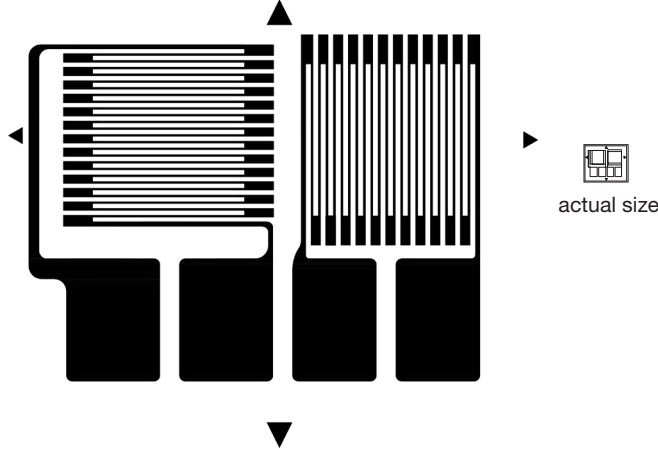

\* Only creep code available for this gage.

Transducer-Class® Strain Gages with Advanced Sensors Technology

<b>S5194 GAGE PATTERN DATA</b>			
	<b>GAGE DESIGNATION</b>	<b>RESISTANCE IN OHMS</b>	<b>STD. CREEP CODE</b>
	N2A-XX-S5194T-10C/E5	1000 ±0.2%	T*
<b>DESCRIPTION</b> General-purpose, four-tab 90° tee rosette.			

<b>GAGE DIMENSIONS</b>						inch	millimeter
Gage Length	Overall Length	Grid Width	Overall Width	Matrix Length	Matrix Width		
0.063	0.142	0.075	0.182	0.19	0.23		
1.60	3.60	1.91	4.62	4.9	5.8		

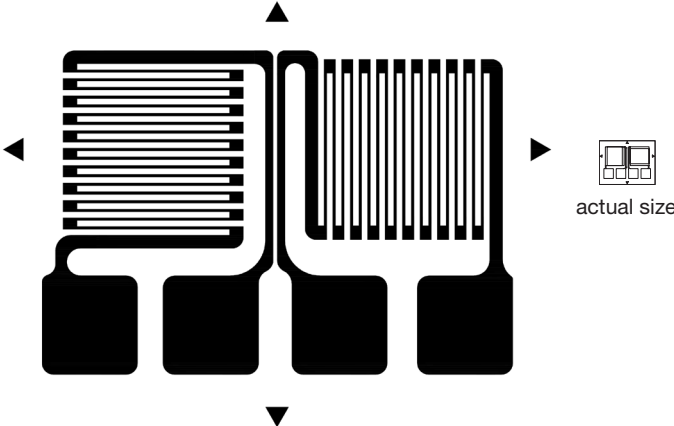

\* Only creep code available for this gage.

<b>S5226 GAGE PATTERN DATA</b>			
	<b>GAGE DESIGNATION</b>	<b>RESISTANCE IN OHMS</b>	<b>STD. CREEP CODE</b>
	N2A-XX-S5226M-10C/E5	1000 ±0.2%	M*
<b>DESCRIPTION</b> General-purpose, four-tab 90° tee rosette.			

<b>GAGE DIMENSIONS</b>						inch	millimeter
Gage Length	Overall Length	Grid Width	Overall Width	Matrix Length	Matrix Width		
0.079	0.165	0.098	0.243	0.23	0.29		
2.01	4.20	2.50	6.18	5.8	7.4		

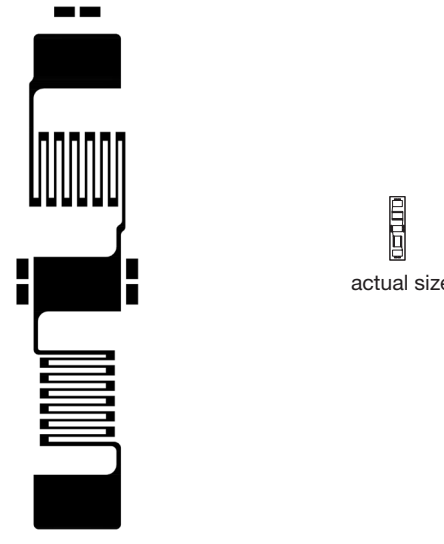

\* Only creep code available for this gage.

Transducer-Class® Strain Gages with Advanced Sensors Technology

S5045 GAGE PATTERN DATA			
	<b>GAGE DESIGNATION</b>	<b>RESISTANCE IN OHMS</b>	<b>STD. CREEP CODE</b>
	N2K-XX-S5045H-10C/DG/E5 N5K-XX-S5045H-10C/DG/E5	1000 ±0.2% 1000 ±0.2%	H* H*
<b>DESCRIPTION</b> Often used on small column transducers.			 <b>RoHS COMPLIANT</b>

GAGE DIMENSIONS						inch	millimeter
Gage Length	Overall Length	Grid Width	Overall Width	Matrix Length	Matrix Width		
0.033	0.291	0.056	0.056	0.33	0.08		
0.80	7.40	1.40	1.40	8.4	2.0		

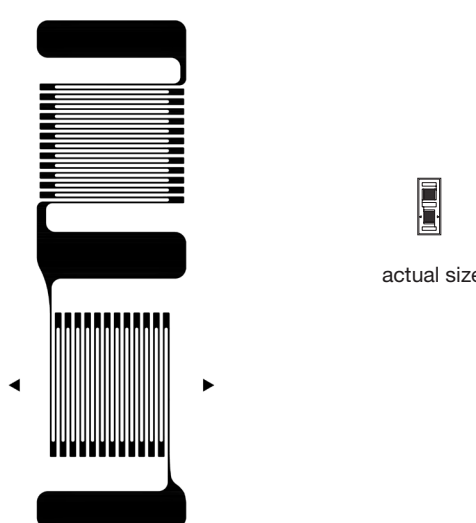

\* Only creep code available for this gage.  
Copper plating for tabs is available.

S5204 GAGE PATTERN DATA			
	<b>GAGE DESIGNATION</b>	<b>RESISTANCE IN OHMS</b>	<b>STD. CREEP CODE</b>
	N2A-XX-S5204Q-350/E5	350 ±0.2%	Q*
<b>DESCRIPTION</b> Often used on column transducers.			 <b>RoHS COMPLIANT</b>

GAGE DIMENSIONS						inch	millimeter
Gage Length	Overall Length	Grid Width	Overall Width	Matrix Length	Matrix Width		
0.062	0.272	0.062	0.080	0.31	0.12		
1.57	6.92	1.57	2.03	7.9	3.0		

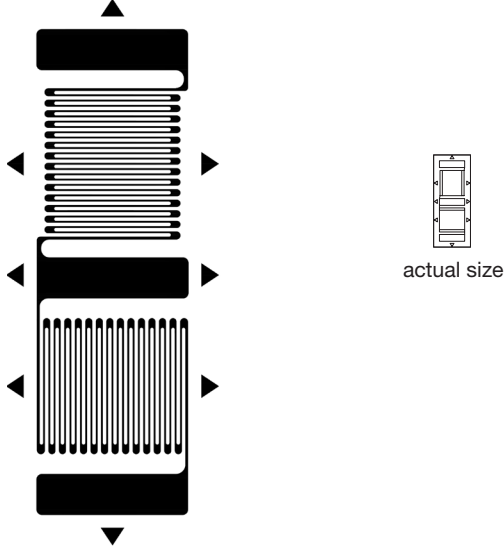

\* Only creep code available for this gage.

Transducer-Class® Strain Gages with Advanced Sensors Technology

S5248 GAGE PATTERN DATA			
 <p>actual size</p>	<b>GAGE DESIGNATION</b>	<b>RESISTANCE IN OHMS</b>	<b>STD. CREEP CODE</b>
	N2A-XX-S5248P-350/E5	350 ±0.2%	P*
<b>DESCRIPTION</b>			 <p>RoHS COMPLIANT</p>
Often used on column transducers.			

GAGE DIMENSIONS						inch	millimeter
Gage Length	Overall Length	Grid Width	Overall Width	Matrix Length	Matrix Width		
0.100	0.415	0.130	0.130	0.48	0.19		
2.54	10.54	3.30	3.30	12.1	4.8		

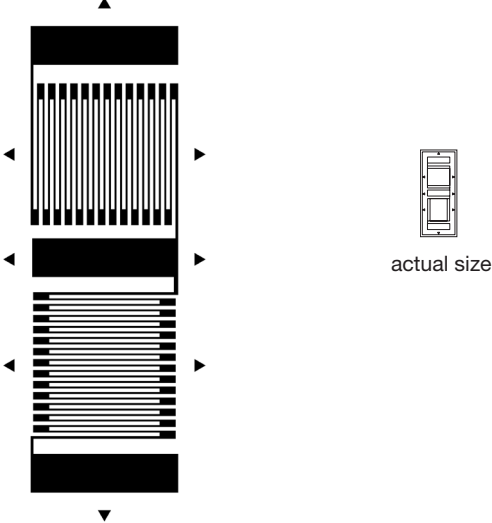
\* Only creep code available for this gage.



S5086 GAGE PATTERN DATA			
 <p>actual size</p>	<b>GAGE DESIGNATION</b>	<b>RESISTANCE IN OHMS</b>	<b>STD. CREEP CODE</b>
	N2K-XX-S5086V-10C/DG/E3 N5K-XX-S5086V-10C/DG/E3	1000 ±0.2% 1000 ±0.2%	V* V*
<b>DESCRIPTION</b>			 <p>RoHS COMPLIANT</p>
Often used on column transducers.			

GAGE DIMENSIONS						inch	millimeter
Gage Length	Overall Length	Grid Width	Overall Width	Matrix Length	Matrix Width		
0.100	0.415	0.130	0.130	0.48	0.19		
2.54	10.54	3.30	3.30	12.1	4.8		

\* Only creep code available for this gage.  
Copper plating for tabs is available.



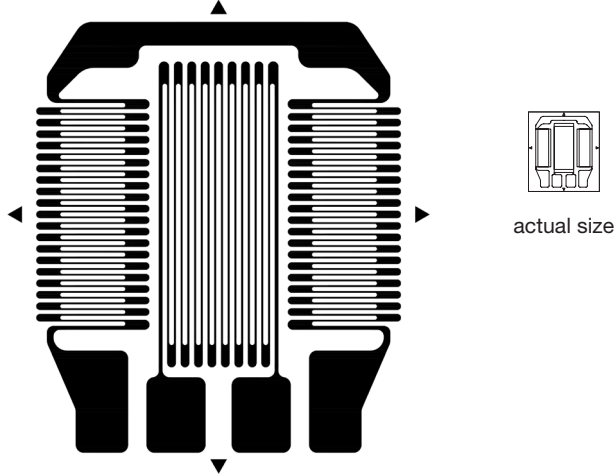

Transducer-Class® Strain Gages with Advanced Sensors Technology

S5257 GAGE PATTERN DATA			
	<b>GAGE DESIGNATION</b>	<b>RESISTANCE IN OHMS</b>	<b>STD. CREEP CODE</b>
	N2A-XX-S5257Y-350/E5	350 ±0.2%	Y*
<b>DESCRIPTION</b> Used on high-accuracy column load cells. (1) Gage length is 0.200 in (5.1 mm). (2) Transverse gage length is 0.050 in (1.27 mm).			

GAGE DIMENSIONS					
				inch	millimeter
<b>Gage Length</b>	<b>Overall Length</b>	<b>Grid Width</b>	<b>Overall Width</b>	<b>Matrix Length</b>	<b>Matrix Width</b>
(1)	0.294	(2)	0.242	0.37	0.33
(1)	7.48	(2)	6.14	9.4	8.4

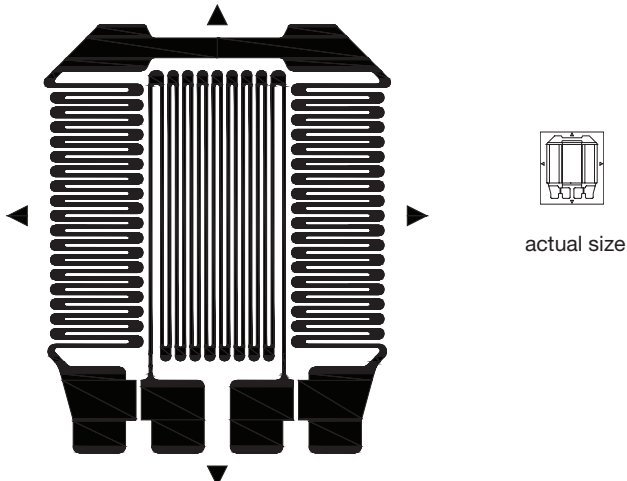

\* Only creep code available for this gage.

GAGE PATTERN DATA			
	<b>GAGE DESIGNATION</b>	<b>RESISTANCE IN OHMS</b>	<b>STD. CREEP CODE</b>
	N2A-XX-S5345R-700/E5 N2A-XX-S5346T-10C/E5	700 ±0.2% 1000 ±0.2%	R* T*
<b>DESCRIPTION</b> Used on high-accuracy column load cells. (1) Gage length is 0.200 in (5.1 mm). (2) Transverse gage length is 0.050 in (1.27mm).			

GAGE DIMENSIONS					
				inch	millimeter
<b>Gage Length</b>	<b>Overall Length</b>	<b>Grid Width</b>	<b>Overall Width</b>	<b>Matrix Length</b>	<b>Matrix Width</b>
(1)	0.325	(2)	0.240	0.38	0.33
(1)	8.25	(2)	6.10	9.5	8.4

\* Only creep code available for this gage.

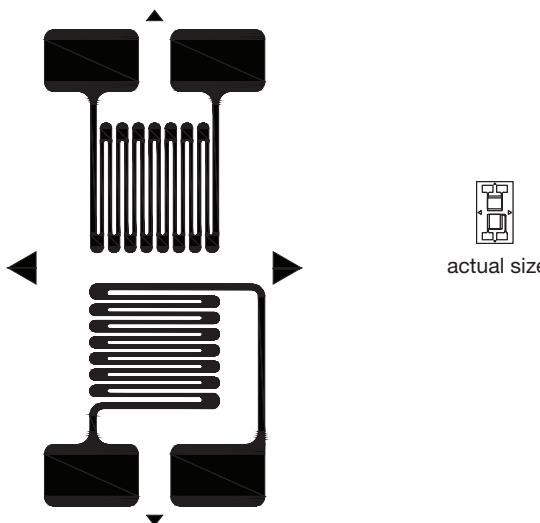

*Transducer-Class®* Strain Gages with Advanced Sensors Technology

<b>S5376 GAGE PATTERN DATA</b>			
 <p>actual size</p>	<b>GAGE DESIGNATION</b>	<b>RESISTANCE IN OHMS</b>	<b>STD. CREEP CODE</b>
	N2A-XX-S5376H-350/E3	350 ±0.2%	H*
<b>DESCRIPTION</b> Miniature 90° tee rosette with tabs on opposite sides			

<b>GAGE DIMENSIONS</b>					
				<b>inch</b>	<b>millimeter</b>
<b>Gage Length</b>	<b>Overall Length</b>	<b>Grid Width</b>	<b>Overall Width</b>	<b>Matrix Length</b>	<b>Matrix Width</b>
0.030	0.147	0.040	0.067	0.17	0.10
0.75	3.74	1.00	1.72	4.3	2.5

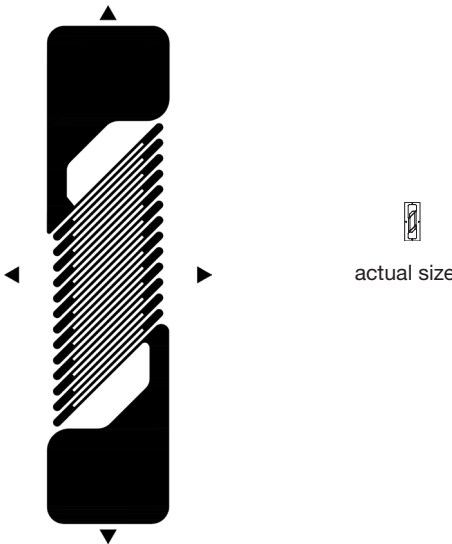

\* Only creep code available for this gage.

## Transducer-Class® Strain Gages with Advanced Sensors Technology

GAGE PATTERN DATA			
	GAGE DESIGNATION	RESISTANCE IN OHMS	STD. CREEP CODE
	N2K-XX-S5218Q-350/DG/E5 N5K-XX-S5218Q-350/DG/E5 N2K-XX-S5033Q-10C/DG/E5 N5K-XX-S5033Q-10C/DG/E5 N2K-XX-S5034Q-50C/DG/E5 N5K-XX-S5034Q-50C/DG/E5	350 ±0.2% 350 ±0.2% 1000 ±0.2% 1000 ±0.2% 5000 ±0.2% 5000 ±0.2%	Q* Q* Q Q Q Q
<b>DESCRIPTION</b> Single-element miniature shear pattern.			 <b>RoHS</b> COMPLIANT

GAGE DIMENSIONS					
				inch	millimeter
Gage Length	Overall Length	Grid Width	Overall Width	Matrix Length	Matrix Width
0.034	0.173	0.050	0.042	0.19	0.08
0.86	4.39	1.27	1.07	4.9	2.0

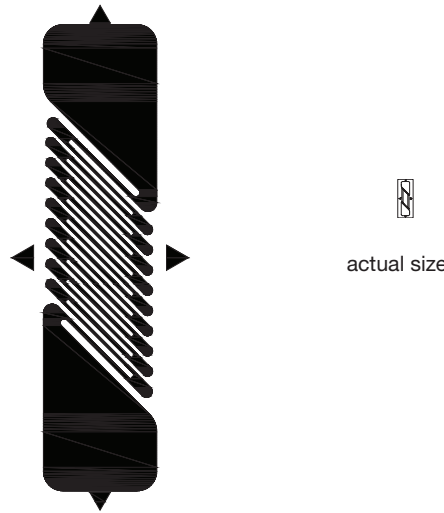

\* Only creep code available for this gage.  
Copper plating for tabs is available.

S5276 GAGE PATTERN DATA			
	GAGE DESIGNATION	RESISTANCE IN OHMS	STD. CREEP CODE
	N2K-XX-S5276Q-10C/DG/E5 N5K-XX-S5276Q-10C/DG/E5	1000 ±0.2% 1000 ±0.2%	Q* Q*
<b>DESCRIPTION</b> Right-hand version of S5033.			 <b>RoHS</b> COMPLIANT

GAGE DIMENSIONS					
				inch	millimeter
Gage Length	Overall Length	Grid Width	Overall Width	Matrix Length	Matrix Width
0.034	0.173	0.050	0.042	0.19	0.08
0.85	4.39	1.27	1.07	4.9	2.0

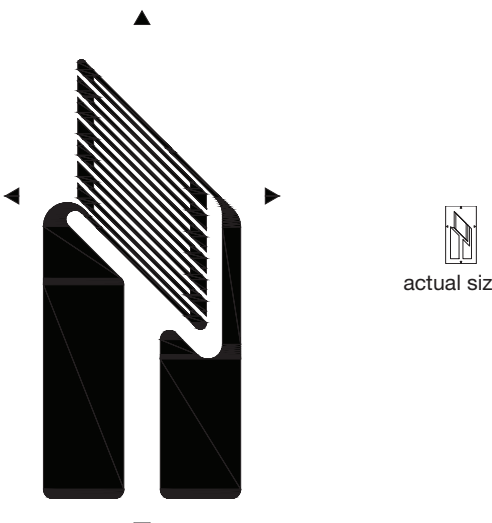

\* Only creep code available for this gage.  
Copper plating for tabs is available.

**Transducer-Class® Strain Gages with Advanced Sensors Technology**

<b>GAGE PATTERN DATA</b>			
 <p>actual size</p>	GAGE DESIGNATION	RESISTANCE IN OHMS	STD. CREEP CODE
	N2K-XX-S5125T-350/DG/E3	350 ±0.2%	T*
	N5K-XX-S5125T-350/DG/E3	350 ±0.2%	T*
	N2K-XX-S5102T-10C/DG/E3	1000 ±0.2%	T*
	N5K-XX-S5102T-10C/DG/E3	1000 ±0.2%	T*
<b>DESCRIPTION</b> Single-element shear pattern with tabs on one end.			 <b>RoHS</b> COMPLIANT

<b>GAGE DIMENSIONS</b>					
				inch	millimeter
Gage Length	Overall Length	Grid Width	Overall Width	Matrix Length	Matrix Width
0.075	0.255	0.060	0.108	0.30	0.16
1.90	6.48	1.52	2.74	7.5	4.0

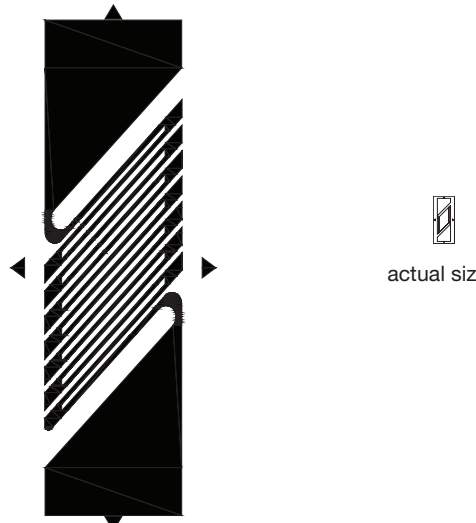

\* Only creep code available for this gage.  
Copper plating for tabs is available.

<b>S5282 GAGE PATTERN DATA</b>			
 <p>actual size</p>	GAGE DESIGNATION	RESISTANCE IN OHMS	STD. CREEP CODE
	N2K-XX-S5282T-350/DG/E4	350 ±0.2%	T*
	N5K-XX-S5282T-350/DG/E4	350 ±0.2%	T*
<b>DESCRIPTION</b> Single-element shear pattern.			 <b>RoHS</b> COMPLIANT

<b>GAGE DIMENSIONS</b>					
				inch	millimeter
Gage Length	Overall Length	Grid Width	Overall Width	Matrix Length	Matrix Width
0.075	0.240	0.059	0.070	0.25	0.11
1.91	6.14	1.50	1.78	6.4	2.9

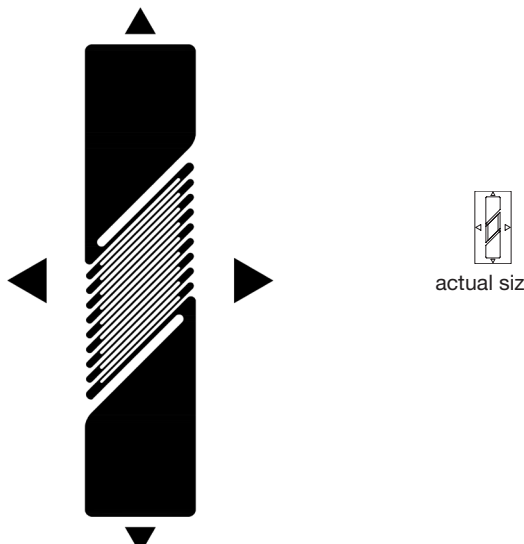

\* Only creep code available for this gage.  
Copper plating for tabs is available.

Transducer-Class® Strain Gages with Advanced Sensors Technology

S5358 GAGE PATTERN DATA			
	<b>GAGE DESIGNATION</b>	<b>RESISTANCE IN OHMS</b>	<b>STD. CREEP CODE</b>
	N2A-XX-S5358T-350/E4	350 ±0.2%	T*
<b>DESCRIPTION</b> Single-element shear pattern.			 <b>RoHS</b> COMPLIANT

GAGE DIMENSIONS						inch	millimeter
Gage Length	Overall Length	Grid Width	Overall Width	Matrix Length	Matrix Width		
0.075	0.320	0.060	0.075	0.38	0.19		
1.91	8.13	1.52	1.91	9.6	4.8		

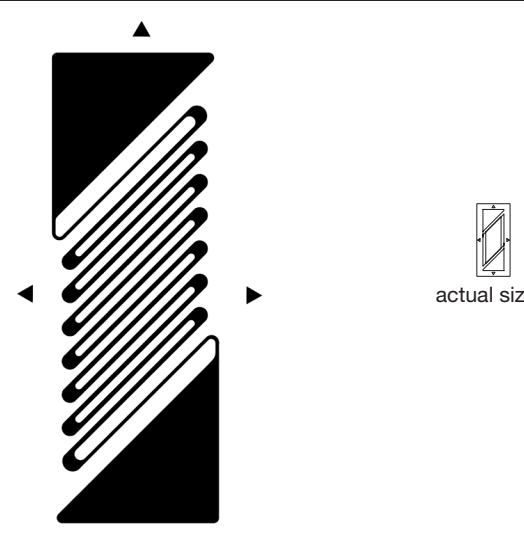

\* Only creep code available for this gage.

S5183 GAGE PATTERN DATA			
	<b>GAGE DESIGNATION</b>	<b>RESISTANCE IN OHMS</b>	<b>STD. CREEP CODE</b>
	N2K-XX-S5183U-175/DG/E4 N5K-XX-S5183U-175/DG/E4	175 ±0.15% 175 ±0.15%	U* U*
<b>DESCRIPTION</b> Single-element shear pattern.			 <b>RoHS</b> COMPLIANT

GAGE DIMENSIONS						inch	millimeter
Gage Length	Overall Length	Grid Width	Overall Width	Matrix Length	Matrix Width		
0.113	0.320	0.116	0.110	0.38	0.17		
2.87	8.12	2.95	2.79	9.7	4.4		

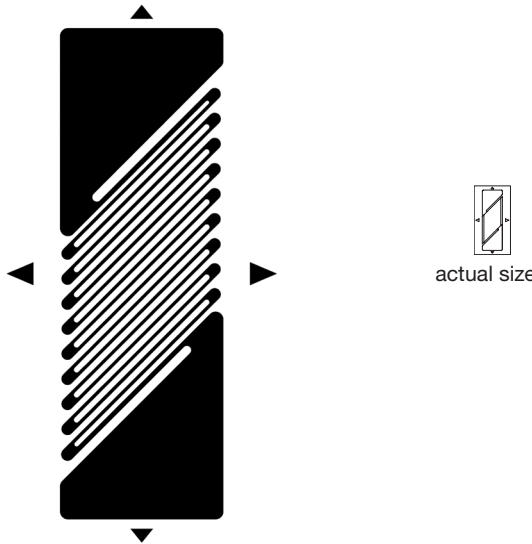

Copper plating for tabs is available.

Transducer-Class® Strain Gages with Advanced Sensors Technology

<b>S5303 GAGE PATTERN DATA</b>			
	<b>GAGE DESIGNATION</b>	<b>RESISTANCE IN OHMS</b>	<b>STD. CREEP CODE</b>
	N2A-XX-S5303R-350/E5	350 ±0.2%	R*
<b>DESCRIPTION</b>			 <b>RoHS COMPLIANT</b>
Single-element shear pattern.			

<b>GAGE DIMENSIONS</b>						<b>inch</b>	<b>millimeter</b>
<b>Gage Length</b>	<b>Overall Length</b>	<b>Grid Width</b>	<b>Overall Width</b>	<b>Matrix Length</b>	<b>Matrix Width</b>		
0.125	0.316	0.102	0.105	0.36	0.19		
3.17	8.02	2.59	2.66	9.1	4.8		

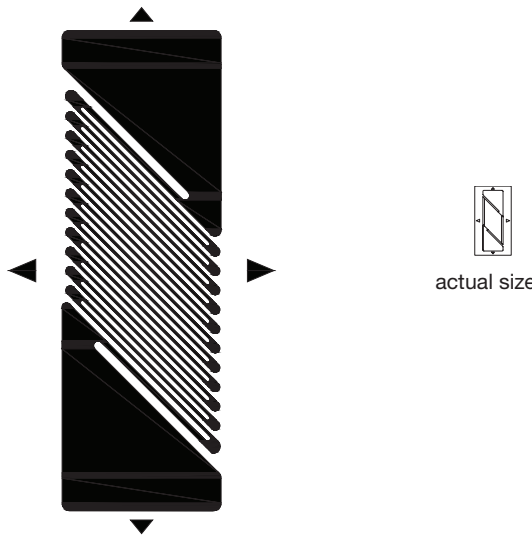

\* Only creep code available for this gage.

<b>S5306 GAGE PATTERN DATA</b>			
	<b>GAGE DESIGNATION</b>	<b>RESISTANCE IN OHMS</b>	<b>STD. CREEP CODE</b>
	N2A-XX-S5306X-350/E5	350 ±0.2%	X*
<b>DESCRIPTION</b>			 <b>RoHS COMPLIANT</b>
Right-hand version of S5303.			

<b>GAGE DIMENSIONS</b>						<b>inch</b>	<b>millimeter</b>
<b>Gage Length</b>	<b>Overall Length</b>	<b>Grid Width</b>	<b>Overall Width</b>	<b>Matrix Length</b>	<b>Matrix Width</b>		
0.125	0.316	0.100	0.105	0.36	0.19		
3.17	8.02	2.54	2.66	9.1	4.8		

\* Only creep code available for this gage.

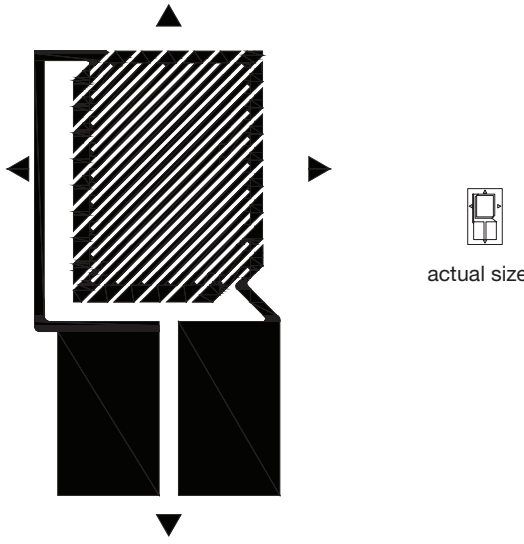

Transducer-Class® Strain Gages with Advanced Sensors Technology

S5061 GAGE PATTERN DATA			
 <p>actual size</p>	GAGE DESIGNATION	RESISTANCE IN OHMS	STD. CREEP CODE
	N2K-XX-S5061Q-50C/DP/E5 N5K-XX-S5061Q-50C/DP/E5	5000 ±0.2% 5000 ±0.2%	Q* Q*
<b>DESCRIPTION</b> High-resistance single-element shear pattern with tabs on one side.			

GAGE DIMENSIONS					
				inch	millimeter
Gage Length	Overall Length	Grid Width	Overall Width	Matrix Length	Matrix Width
0.120	0.232	0.136	0.115	0.28	0.18
3.05	5.89	3.45	2.92	7.2	4.4

\* Only creep code available for this gage.  
Copper plating for tabs is available.

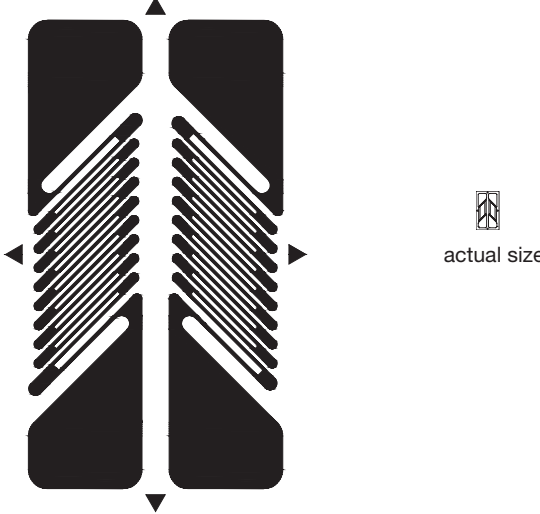
**Transducer-Class® Strain Gages with Advanced Sensors Technology**

<b>GAGE PATTERN DATA</b>			
	<b>GAGE DESIGNATION</b>	<b>RESISTANCE IN OHMS</b>	<b>STD. CREEP CODE</b>
	N2K-XX-S5136Q-175/DG/E4 N5K-XX-S5136Q-175/DG/E4 N2K-XX-S5130Q-350/DG/E4 N5K-XX-S5130Q-350/DG/E4 N2K-XX-S5278Q-500/DG/E5 N5K-XX-S5278Q-500/DG/E5 N2K-XX-S5064Q-10C/DG/E5 N5K-XX-S5064Q-10C/DG/E5	175 ±0.2% 175 ±0.2% 350 ±0.2% 350 ±0.2% 500 ±0.2% 500 ±0.2% 1000 ±0.2% 1000 ±0.2%	Q* Q* Q* Q* Q* Q* Q* Q*
<b>DESCRIPTION</b> Dual-element pattern for shear or torque transducers.			



<b>GAGE DIMENSIONS</b>					
				<b>inch</b>	<b>millimeter</b>
<b>Gage Length</b>	<b>Overall Length</b>	<b>Grid Width</b>	<b>Overall Width</b>	<b>Matrix Length</b>	<b>Matrix Width</b>
0.034	0.160	0.050	0.094	0.19	0.12
0.86	4.06	1.27	2.38	4.9	2.9

\* Only creep code available for this gage.

\*\*\* For S5136, matrix length is 0.22 in (5.6 mm)

\*\* Overall Length dimensions may differ from pattern to pattern.

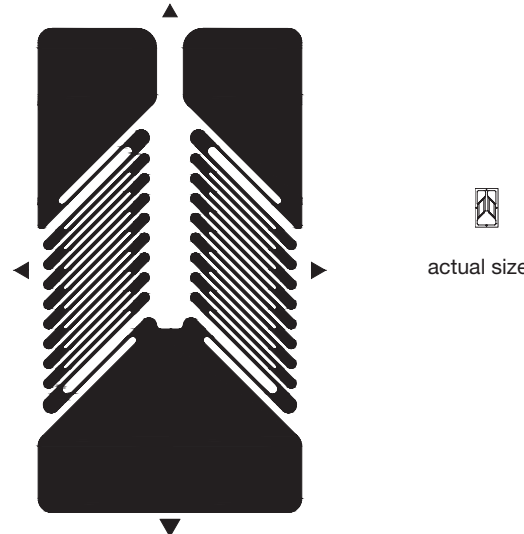
Copper plating for tabs is available.



<b>S5208 GAGE PATTERN DATA</b>			
	<b>GAGE DESIGNATION</b>	<b>RESISTANCE IN OHMS</b>	<b>STD. CREEP CODE</b>
	N2K-XX-S5208Q-350/DG/E5 N5K-XX-S5208Q-350/DG/E5	350 ±0.2% 350 ±0.2%	Q* Q*
<b>DESCRIPTION</b> Dual-element pattern for shear or torque transducers			

<b>GAGE DIMENSIONS</b>					
				<b>inch</b>	<b>millimeter</b>
<b>Gage Length</b>	<b>Overall Length</b>	<b>Grid Width</b>	<b>Overall Width</b>	<b>Matrix Length</b>	<b>Matrix Width</b>
0.034	0.173	0.050	0.094	0.20	0.12
0.85	4.39	1.27	2.39	5.0	3.0

\* Only creep code available for this gage.  
Copper plating for tabs is available.



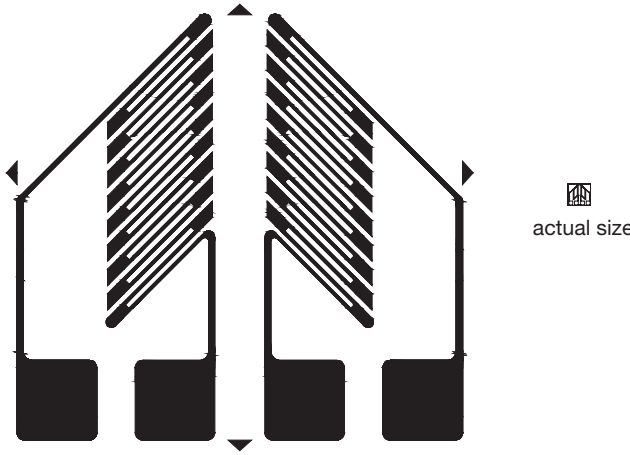

Transducer-Class® Strain Gages with Advanced Sensors Technology

GAGE PATTERN DATA			
	GAGE DESIGNATION	RESISTANCE IN OHMS	STD. CREEP CODE
	N2K-XX-S5035Q-10C/DG/E5 N5K-XX-S5035Q-10C/DG/E5 N2K-XX-S5036Q-50C/DG/E3 N5K-XX-S5036Q-50C/DG/E3	1000 ±0.2% 1000 ±0.2% 5000 ±0.2% 5000 ±0.2%	Q Q Q* Q*
<b>DESCRIPTION</b> Dual-element pattern for shear or torque transducers.			 <b>RoHS</b> COMPLIANT

GAGE DIMENSIONS					
				inch	millimeter
Gage Length	Overall Length	Grid Width	Overall Width	Matrix Length	Matrix Width
0.033	0.148	0.051	0.155	0.16	0.17
0.84	3.76	1.29	3.94	4.1	4.3

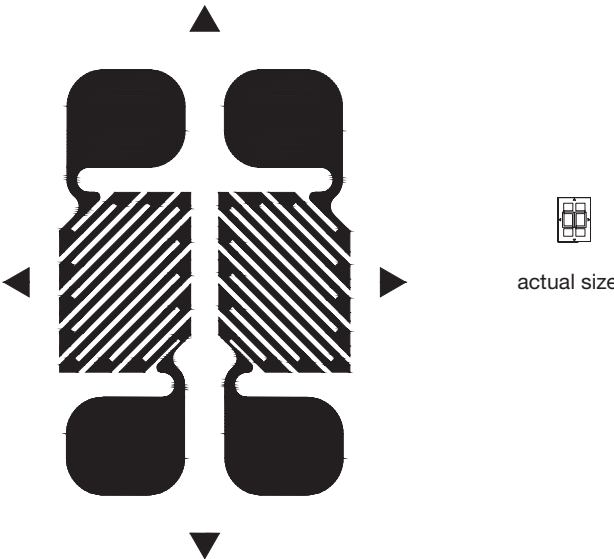

\* Only creep code available for this gage.  
Copper plating for tabs is available.

S5135 GAGE PATTERN DATA			
	GAGE DESIGNATION	RESISTANCE IN OHMS	STD. CREEP CODE
	N2A-XX-S5135M-350/E4	350 ±0.2%	M*
<b>DESCRIPTION</b> Dual-element pattern for shear or torque transducers.			 <b>RoHS</b> COMPLIANT

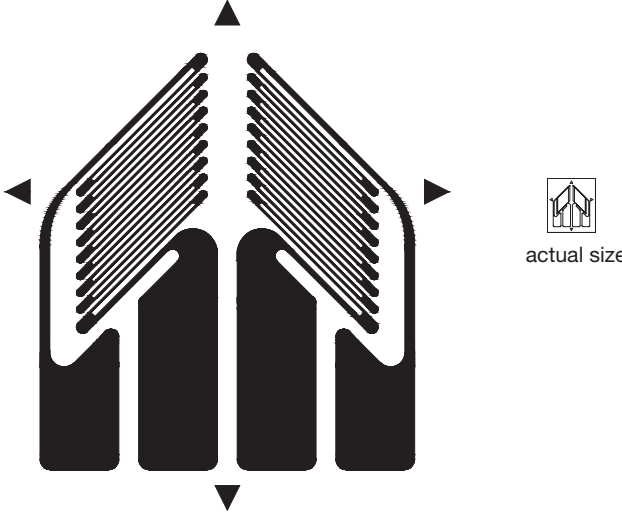

GAGE DIMENSIONS					
				inch	millimeter
Gage Length	Overall Length	Grid Width	Overall Width	Matrix Length	Matrix Width
0.064	0.175	0.070	0.113	0.23	0.17
1.62	4.44	1.77	2.87	6.0	4.4

\* Only creep code available for this gage.

Transducer-Class® Strain Gages with Advanced Sensors Technology

S5095 GAGE PATTERN DATA			
	<b>GAGE DESIGNATION</b>	<b>RESISTANCE IN OHMS</b>	<b>STD. CREEP CODE</b>
	N2A-XX-S5095N-350/E5	350 ±0.2%	N
<b>DESCRIPTION</b> Dual-element pattern for shear or torque transducers.			

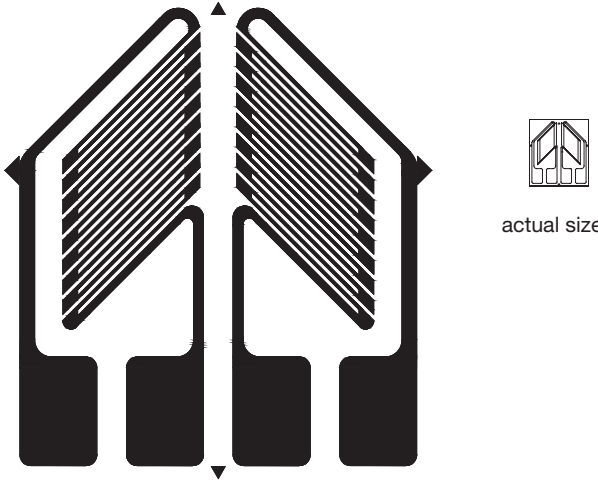

GAGE DIMENSIONS					
				inch	millimeter
Gage Length	Overall Length	Grid Width	Overall Width	Matrix Length	Matrix Width
0.079	0.215	0.056	0.190	0.28	0.25
2.01	5.46	1.43	4.83	7.2	6.4

GAGE PATTERN DATA			
	<b>GAGE DESIGNATION</b>	<b>RESISTANCE IN OHMS</b>	<b>STD. CREEP CODE</b>
	N2K-XX-S5103R-350/DG/E4	350 ±0.2%	R
	N5K-XX-S5103R-350/DG/E4	350 ±0.2%	R
	N2K-XX-S5174Q-10C/DG/E4	1000 ±0.2%	Q*
	N5K-XX-S5174Q-10C/DG/E4	1000 ±0.2%	Q*
	N2K-XX-S5200Q-50C/DG/E4	5000 ±0.2%	Q*
	N5K-XX-S5200Q-50C/DG/E4	5000 ±0.2%	Q*
<b>DESCRIPTION</b> Dual-element pattern for shear or torque transducers			

GAGE DIMENSIONS					
				inch	millimeter
Gage Length	Overall Length	Grid Width	Overall Width	Matrix Length	Matrix Width
0.075	0.231	0.060	0.202	0.25	0.22
1.91	5.86	1.52	5.13	6.3	5.6

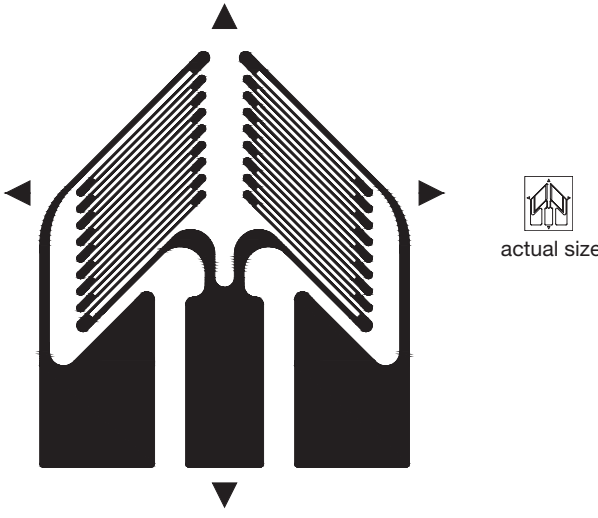

\* Only creep code available for this gage.  
Copper plating for tabs is available.

Transducer-Class® Strain Gages with Advanced Sensors Technology

S5185 GAGE PATTERN DATA			
	<b>GAGE DESIGNATION</b>	<b>RESISTANCE IN OHMS</b>	<b>STD. CREEP CODE</b>
	N2A-XX-S5185T-350/E5	350 ±0.2%	T*
<b>DESCRIPTION</b>			
Three-tab version of S5095 pattern.			

GAGE DIMENSIONS					
				inch	millimeter
<b>Gage Length</b>	<b>Overall Length</b>	<b>Grid Width</b>	<b>Overall Width</b>	<b>Matrix Length</b>	<b>Matrix Width</b>
0.080	0.215	0.056	0.190	0.28	0.25
2.01	5.46	1.43	4.83	7.2	6.4

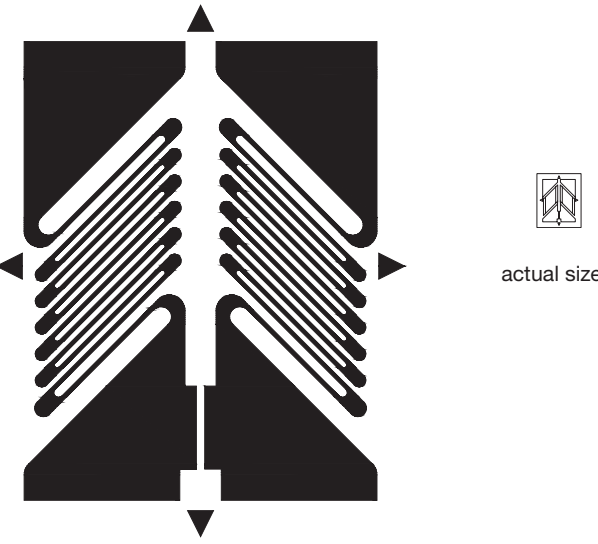
\* Only creep code available for this gage.

GAGE PATTERN DATA					
	<b>GAGE DESIGNATION</b>	<b>RESISTANCE IN OHMS</b>	<b>STD. CREEP CODE</b>		
	N2A-XX-S5291R-350/E5 N2K-XX-S5113R-350/DG/E4 N5K-XX-S5113R-350/DG/E4 N2K-XX-S5116Q-10C/DG/E5 N5K-XX-S5116Q-10C/DG/E5 N2K-XX-S5089Q-25C/DG/E5 N5K-XX-S5089Q-25C/DG/E5 N2K-XX-S5040Q-50C/DG/E5 N5K-XX-S5040Q-50C/DG/E5	350 ±0.2% 350 ±0.2% 350 ±0.2% 1000 ±0.2% 1000 ±0.2% 2500 ±0.3% 2500 ±0.3% 5000 ±0.2% 5000 ±0.2%	R R R Q Q Q* Q* Q Q		
<b>DESCRIPTION</b>					
Dual-element patterns for shear or torque transducers.					
GAGE DIMENSIONS					
				inch	millimeter
<b>Gage Length</b>	<b>Overall Length</b>	<b>Grid Width</b>	<b>Overall Width</b>	<b>Matrix Length</b>	<b>Matrix Width</b>
0.075	0.221	0.060	0.170	0.28	0.23
1.91	5.61	1.52	4.32	7.1	5.8



\* Only creep code available for this gage.

Copper plating for tabs is available.

\*\* Grid dimensions may differ from pattern to pattern.

Transducer-Class® Strain Gages with Advanced Sensors Technology

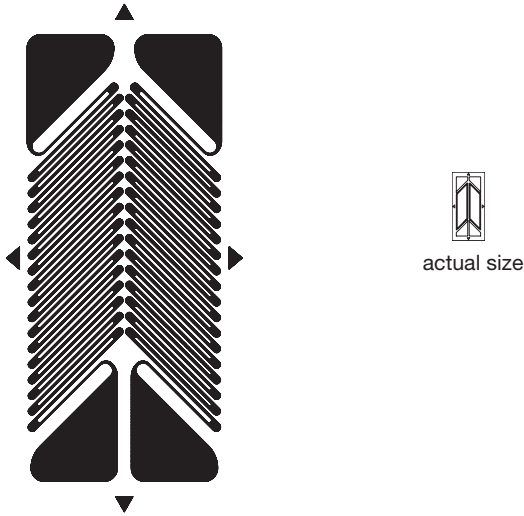

**S5147 GAGE PATTERN DATA**

	<p><b>GAGE DESIGNATION</b></p> <p>N2K-XX-S5147P-10C/DG/E4 N5K-XX-S5147P-10C/DG/E4</p>	<p><b>RESISTANCE IN OHMS</b></p> <p>1000 ±0.2% 1000 ±0.2%</p>	<p><b>STD. CREEP CODE</b></p> <p>P P</p>
	<p><b>DESCRIPTION</b></p> <p>Dual-element pattern for shear or torque transducers.</p>		

GAGE DIMENSIONS					
				inch	millimeter
Gage Length	Overall Length	Grid Width	Overall Width	Matrix Length	Matrix Width
0.071	0.307	0.130	0.126	0.35	0.17
1.80	7.80	3.30	3.20	9.0	4.3

Copper plating for tabs is available.

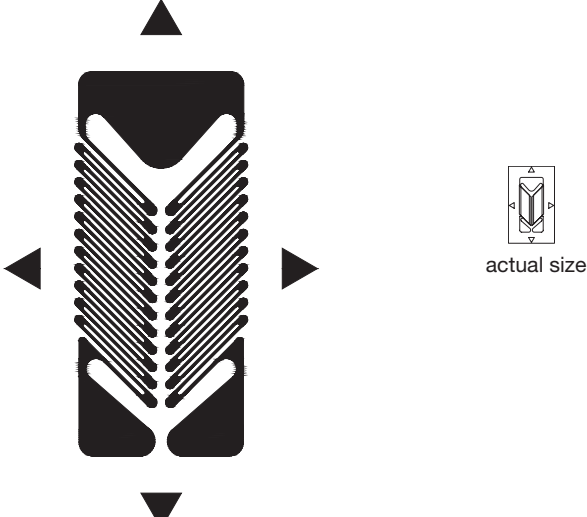

**S5259 GAGE PATTERN DATA**

	<p><b>GAGE DESIGNATION</b></p> <p>N2A-XX-S5259S-350/E5</p>	<p><b>RESISTANCE IN OHMS</b></p> <p>350 ±0.2%</p>	<p><b>STD. CREEP CODE</b></p> <p>S*</p>
	<p><b>DESCRIPTION</b></p> <p>Dual-element pattern for shear or torque transducers.</p>		

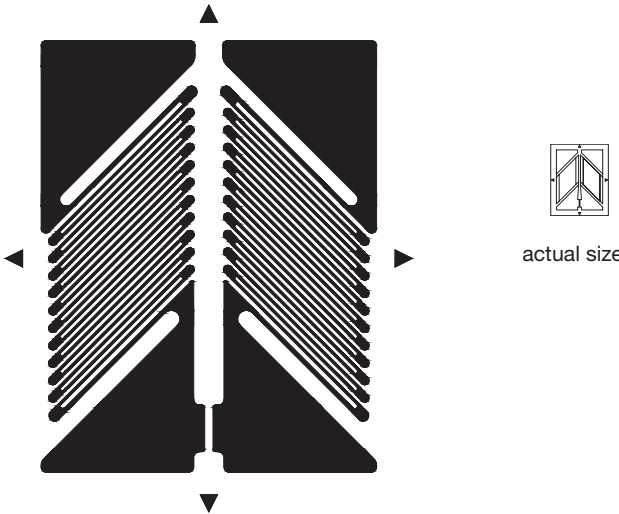

GAGE DIMENSIONS					
				inch	millimeter
Gage Length	Overall Length	Grid Width	Overall Width	Matrix Length	Matrix Width
0.062	0.284	0.106	0.121	0.40	0.24
1.57	7.21	2.69	3.08	10.1	6.1

\* Only creep code available for this gage.

Transducer-Class® Strain Gages with Advanced Sensors Technology

S5162 GAGE PATTERN DATA			
	<b>GAGE DESIGNATION</b>	<b>RESISTANCE IN OHMS</b>	<b>STD. CREEP CODE</b>
	N2A-XX-S5162R-350/E4	350 ±0.2%	R
<b>DESCRIPTION</b> Dual-element pattern for shear or torque transducers.			 <b>RoHS</b> COMPLIANT

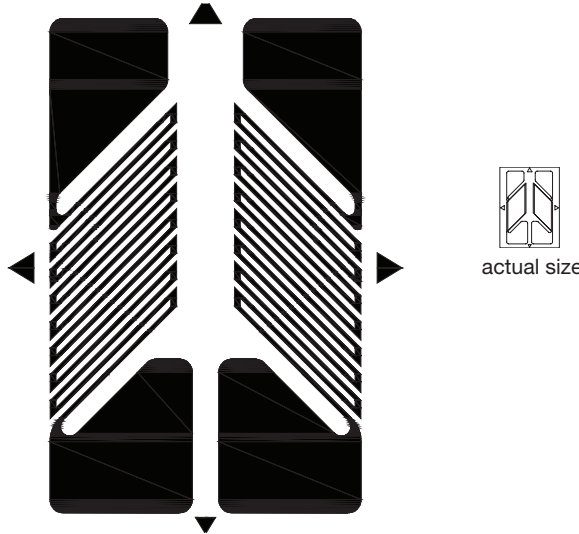
GAGE DIMENSIONS					
				inch	millimeter
<b>Gage Length</b>	<b>Overall Length</b>	<b>Grid Width</b>	<b>Overall Width</b>	<b>Matrix Length</b>	<b>Matrix Width</b>
0.125	0.318	0.100	0.245	0.38	0.30
3.18	8.10	2.54	6.20	9.6	7.7



S5124 GAGE PATTERN DATA			
	<b>GAGE DESIGNATION</b>	<b>RESISTANCE IN OHMS</b>	<b>STD. CREEP CODE</b>
	N2K-XX-S5124K-350/E5 N5K-XX-S5124K-350/E5	350 ±0.2% 350 ±0.2%	K* K*
<b>DESCRIPTION</b> Dual-element pattern for shear or torque transducers.			 <b>RoHS</b> COMPLIANT

GAGE DIMENSIONS					
				inch	millimeter
<b>Gage Length</b>	<b>Overall Length</b>	<b>Grid Width</b>	<b>Overall Width</b>	<b>Matrix Length</b>	<b>Matrix Width</b>
0.125	0.380	0.110	0.240	0.42	0.31
3.18	9.63	2.79	6.06	10.7	7.9

\* Only creep code available for this gage.  
Copper plating for tabs is available.

Transducer-Class® Strain Gages with Advanced Sensors Technology

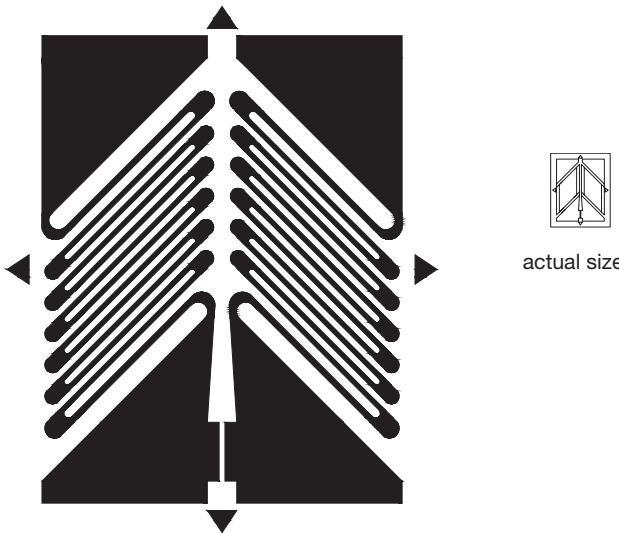

**S5364 GAGE PATTERN DATA**

	<p><b>GAGE DESIGNATION</b></p> <p>N2K-XX-S5364Y-350/DG/E5 N5K-XX-S5364Y-350/DG/E5</p>	<p><b>RESISTANCE IN OHMS</b></p> <p>350 ±0.2%</p>	<p><b>STD. CREEP CODE</b></p> <p>Y*</p>
	<p><b>DESCRIPTION</b></p> <p>Dual-element pattern for shear or torque transducers</p>		 <p><b>RoHS COMPLIANT</b></p>

GAGE DIMENSIONS				inch	millimeter
Gage Length	Overall Length	Grid Width	Overall Width	Matrix Length	Matrix Width
0.125	0.318	0.100	0.245	0.38	0.31
3.17	8.08	2.54	6.23	9.6	7.8

\* Only creep code available for this gage.  
Copper plating for tabs is available.

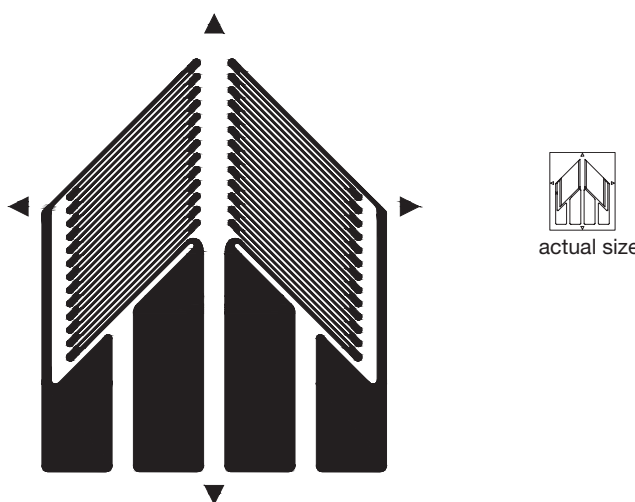

**S5243 GAGE PATTERN DATA**

	<p><b>GAGE DESIGNATION</b></p> <p>N2A-XX-S5243T-10C/E5</p>	<p><b>RESISTANCE IN OHMS</b></p> <p>1000 ±0.2%</p>	<p><b>STD. CREEP CODE</b></p> <p>Q*</p>
	<p><b>DESCRIPTION</b></p> <p>Dual-element pattern for shear or torque transducers</p>		 <p><b>RoHS COMPLIANT</b></p>

GAGE DIMENSIONS				inch	millimeter
Gage Length	Overall Length	Grid Width	Overall Width	Matrix Length	Matrix Width
0.125	0.334	0.100	0.275	0.40	0.34
3.17	8.48	2.54	7.00	10.1	8.5

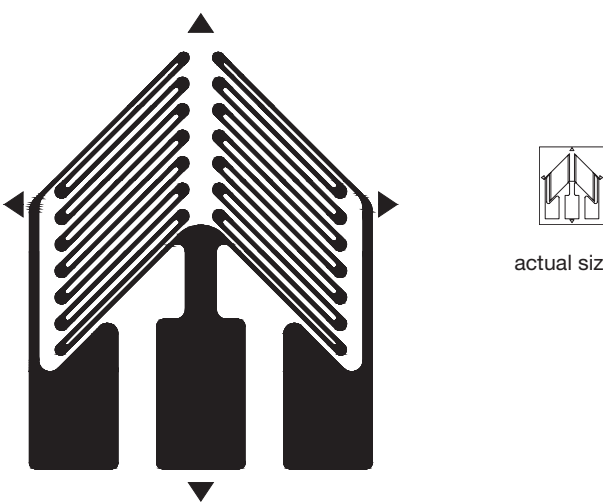

\* Only creep code available for this gage.

Transducer-Class® Strain Gages with Advanced Sensors Technology

S5293 GAGE PATTERN DATA			
 <p>actual size</p>	<b>GAGE DESIGNATION</b>	<b>RESISTANCE IN OHMS</b>	<b>STD. CREEP CODE</b>
	N2A-XX-S5293P-350/E5	350 ±0.2%	P*
<b>DESCRIPTION</b> Dual-element pattern for shear or torque transducers			

GAGE DIMENSIONS					
				inch	millimeter
<b>Gage Length</b>	<b>Overall Length</b>	<b>Grid Width</b>	<b>Overall Width</b>	<b>Matrix Length</b>	<b>Matrix Width</b>
0.125	0.334	0.100	0.275	0.40	0.34
3.17	8.48	2.54	7.00	10.1	8.5

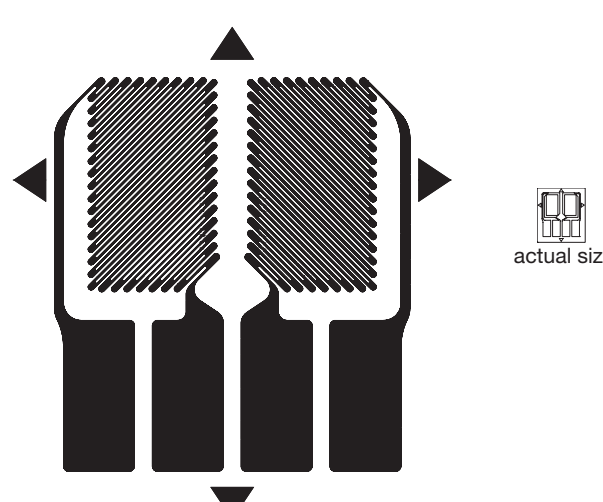
\* Only creep code available for this gage.

S5321 GAGE PATTERN DATA			
 <p>actual size</p>	<b>GAGE DESIGNATION</b>	<b>RESISTANCE IN OHMS</b>	<b>STD. CREEP CODE</b>
	N2A-XX-S5321R-10C/E5	1000 ±0.2%	R*
<b>DESCRIPTION</b> Dual-element pattern for shear or torque transducers			

GAGE DIMENSIONS					
				inch	millimeter
<b>Gage Length</b>	<b>Overall Length</b>	<b>Grid Width</b>	<b>Overall Width</b>	<b>Matrix Length</b>	<b>Matrix Width</b>
0.085	0.218	0.119	0.190	0.28	0.25
2.16	5.54	3.02	4.83	7.2	6.4

*Transducer-Class*® Strain Gages with Advanced Sensors Technology

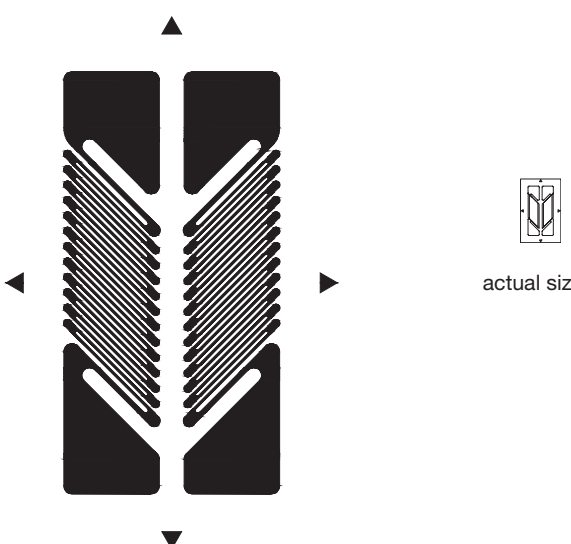

<b>S5283 GAGE PATTERN DATA</b>			
 <p>actual size</p>	<b>GAGE DESIGNATION</b>  N2A-XX-S5283Q-500/E5	<b>RESISTANCE IN OHMS</b>  500 ±0.2%	<b>STD. CREEP CODE</b>  Q*
	<b>DESCRIPTION</b>  Dual-element pattern for shear or torque transducers.		

<b>GAGE DIMENSIONS</b>					
				inch	millimeter
Gage Length	Overall Length	Grid Width	Overall Width	Matrix Length	Matrix Width
0.062	0.256	0.089	0.131	0.33	0.21
1.57	6.50	2.26	3.33	8.4	5.3

\* Only creep code available for this gage.



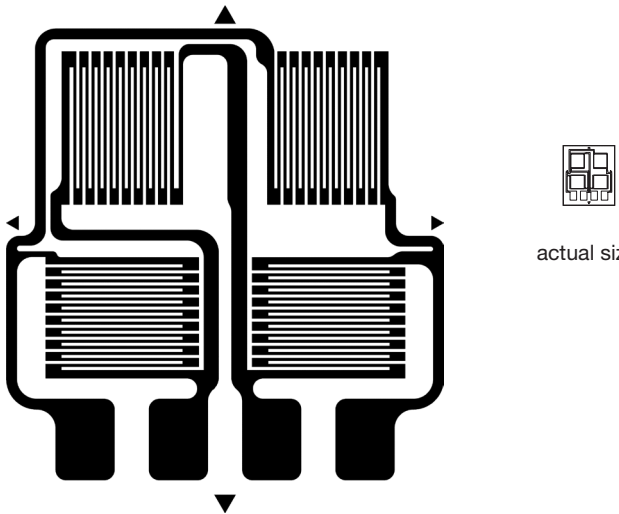

## Transducer-Class® Strain Gages with Advanced Sensors Technology

S5056 GAGE PATTERN DATA			
 <p>actual size</p>	<b>GAGE DESIGNATION</b>	<b>RESISTANCE IN OHMS</b>	<b>STD. CREEP CODE</b>
	N2K-XX-S5056Q-10C/DG/E5 N5K-XX-S5056Q-10C/DG/E5	1000 ±3% 1000 ±3%	Q* Q*
<b>DESCRIPTION</b> Full-bridge for bending-beam transducers. Bridge is balanced to ±0.4 mV/V, but RG is 1000 Ω ±3%.			

GAGE DIMENSIONS					
				inch	millimeter
<b>Gage Length</b>	<b>Overall Length</b>	<b>Grid Width</b>	<b>Overall Width</b>	<b>Matrix Length</b>	<b>Matrix Width</b>
0.070	0.262	0.070	0.253	0.31	0.27
1.78	6.66	1.78	6.43	7.9	6.8

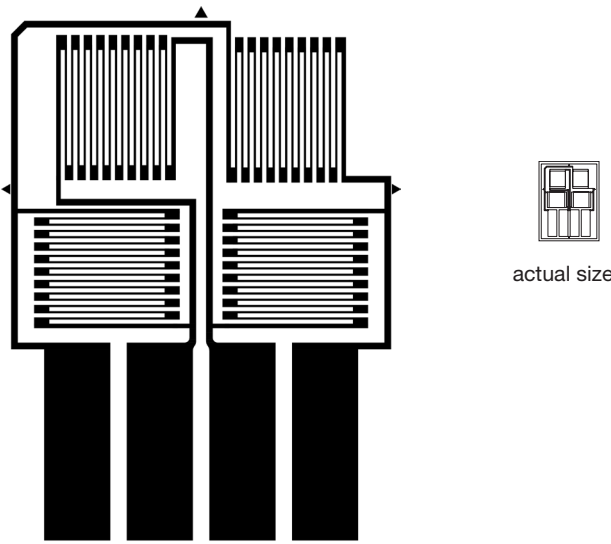

\* Only creep code available for this gage.  
Copper plating for tabs is available.

S5107 GAGE PATTERN DATA			
 <p>actual size</p>	<b>GAGE DESIGNATION</b>	<b>RESISTANCE IN OHMS</b>	<b>STD. CREEP CODE</b>
	N2K-XX-S5107Q-12C/DG/E5 N5K-XX-S5107Q-12C/DG/E5	1200 ±3% 1200 ±3%	Q* Q*
<b>DESCRIPTION</b> Full-bridge for bending-beam transducers. Bridge is balanced to ±0.4 mV/V, but RG is a 1200 Ω ±3%.			

GAGE DIMENSIONS					
				inch	millimeter
<b>Gage Length</b>	<b>Overall Length</b>	<b>Grid Width</b>	<b>Overall Width</b>	<b>Matrix Length</b>	<b>Matrix Width</b>
0.070	0.302	0.070	0.190	0.34	0.25
1.78	7.67	1.78	4.83	8.5	6.4

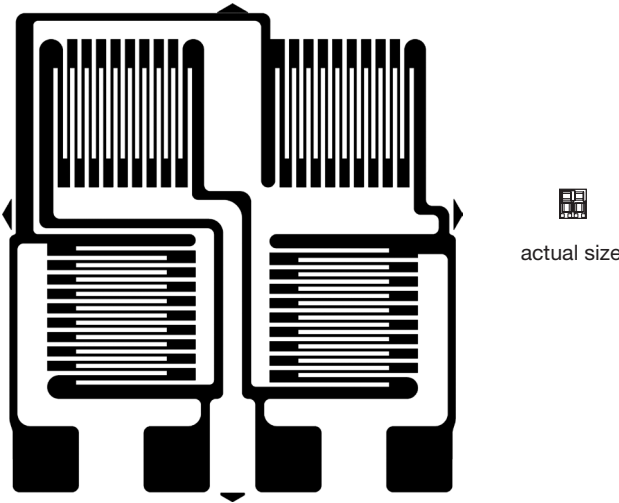

\* Only creep code available for this gage.  
Copper plating for tabs is available.

*Transducer-Class®* Strain Gages with Advanced Sensors Technology

<b>S5229 GAGE PATTERN DATA</b>			
 <p>actual size</p>	<b>GAGE DESIGNATION</b>	<b>RESISTANCE IN OHMS</b>	<b>STD. CREEP CODE</b>
	N2K-XX-S5229A-50C/DG/E3 N5K-XX-S5229A-50C/DG/E3	5000 ±5% 5000 ±5%	A* A*
<b>DESCRIPTION</b> Miniature high resistance full-bridge. Bridge is balanced to ±0.5 mV/V, but RG is 5000 Ω ±5%.			

<b>GAGE DIMENSIONS</b>					
				inch	millimeter
<b>Gage Length</b>	<b>Overall Length</b>	<b>Grid Width</b>	<b>Overall Width</b>	<b>Matrix Length</b>	<b>Matrix Width</b>
0.028	0.129	0.044	0.134	0.16	0.14
0.71	3.30	1.13	3.41	4.0	3.7

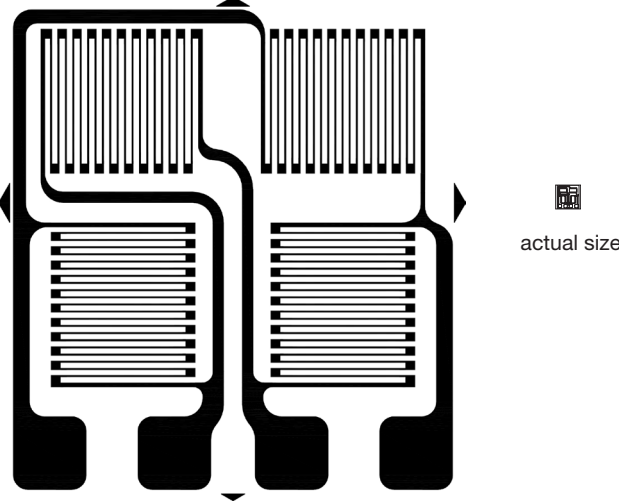

\* Only creep code available for this gage.  
Copper plating for tabs is available.

<b>S5231 GAGE PATTERN DATA</b>			
 <p>actual size</p>	<b>GAGE DESIGNATION</b>	<b>RESISTANCE IN OHMS</b>	<b>STD. CREEP CODE</b>
	N2K-XX-S5231K-20C/DG/E3 N5K-XX-S5231K-20C/DG/E3	2000 ±3% 2000 ±3%	K* K*
<b>DESCRIPTION</b> Miniature high resistance full-bridge. Bridge is balanced to ±0.5 mV/V, but RG is 2000 Ω ±3%.			

<b>GAGE DIMENSIONS</b>					
				inch	millimeter
<b>Gage Length</b>	<b>Overall Length</b>	<b>Grid Width</b>	<b>Overall Width</b>	<b>Matrix Length</b>	<b>Matrix Width</b>
0.020	0.122	0.045	0.120	0.14	0.13
0.51	3.10	1.14	3.05	3.6	3.4

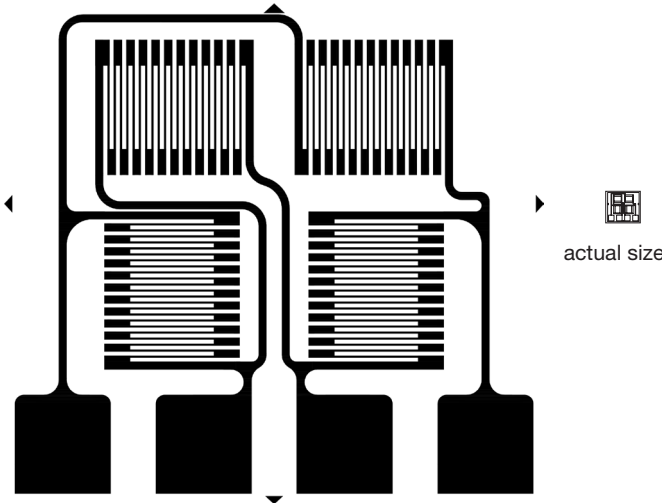

\* Only creep code available for this gage.  
Copper plating for tabs is available.

Transducer-Class® Strain Gages with Advanced Sensors Technology

S5020 GAGE PATTERN DATA			
	GAGE DESIGNATION	RESISTANCE IN OHMS	STD. CREEP CODE
	N2K-XX-S5020Q-50C/DG/E3 N5K-XX-S5020Q-50C/DG/E3	5000 ±5% 5000 ±5%	Q* Q*
<b>DESCRIPTION</b> Miniature high resistance full-bridge. Bridge is balanced to ±0.4 mV/V, but RG is 5000 Ω ±5%.			

GAGE DIMENSIONS					
				inch	millimeter
Gage Length	Overall Length	Grid Width	Overall Width	Matrix Length	Matrix Width
0.028	0.160	0.050	0.159	0.17	0.18
0.71	4.06	1.27	4.03	4.3	4.7

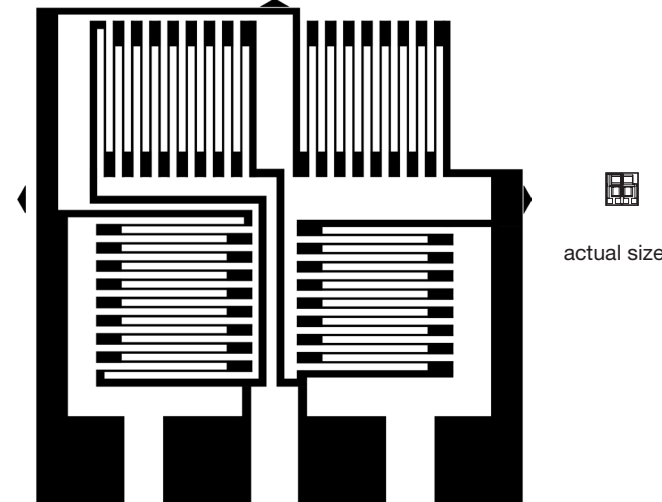

\* Only creep code available for this gage.  
Copper plating for tabs is available.

S5067 GAGE PATTERN DATA			
	GAGE DESIGNATION	RESISTANCE IN OHMS	STD. CREEP CODE
	N2K-XX-S5067P-10C/DG/E5 N5K-XX-S5067P-10C/DG/E5	1000 ±3% 1000 ±3%	P* P*
<b>DESCRIPTION</b> Small full-bridge for bending-beam transducers. Bridge is balanced to ±0.4 mV/V, but RG is 1000 Ω ±3%.			

GAGE DIMENSIONS					
				inch	millimeter
Gage Length	Overall Length	Grid Width	Overall Width	Matrix Length	Matrix Width
0.033	0.153	0.053	0.158	0.17	0.17
0.85	3.89	1.36	4.02	4.3	4.3

\* Only creep code available for this gage.  
Copper plating for tabs is available.

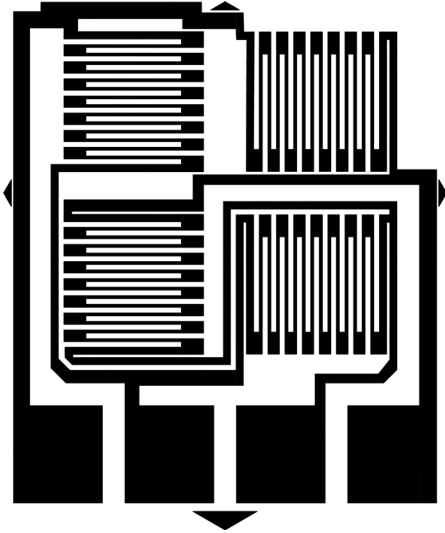
Transducer-Class® Strain Gages with Advanced Sensors Technology

<b>S5062 GAGE PATTERN DATA</b>			
 <p>actual size</p>	<b>GAGE DESIGNATION</b>	<b>RESISTANCE IN OHMS</b>	<b>STD. CREEP CODE</b>
	N2K-XX-S5062N-10C/DG/E5	1000 ±3%	N*
	N5K-XX-S5062N-10C/DG/E5	1000 ±3%	N*
<b>DESCRIPTION</b> Small full-bridge for bending-beam transducers. Bridge is balanced to ±0.4 mV/V, but RG is 1000 Ω ±3%.			 <b>RoHS COMPLIANT</b>

<b>GAGE DIMENSIONS</b>					
				inch	millimeter
<b>Gage Length</b>	<b>Overall Length</b>	<b>Grid Width</b>	<b>Overall Width</b>	<b>Matrix Length</b>	<b>Matrix Width</b>
0.033	0.148	0.057	0.168	0.16	0.19
0.85	3.76	1.45	4.27	4.2	4.8

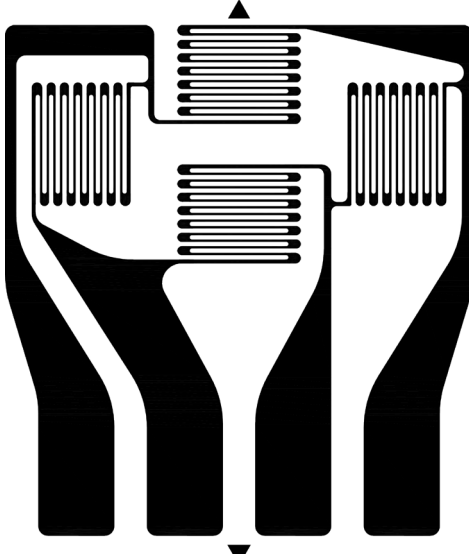

\* Only creep code available for this gage.  
Copper plating for tabs is available.

<b>S5232 GAGE PATTERN DATA</b>			
 <p>actual size</p>	<b>GAGE DESIGNATION</b>	<b>RESISTANCE IN OHMS</b>	<b>STD. CREEP CODE</b>
	N2A-XX-S5232K-350/E5	350 ±3%	K*
	<b>DESCRIPTION</b> Full-bridge for bending-beam transducers. Bridge is balanced to ±0.4 mV/V, but RG is 350 Ω ±3%.		

<b>GAGE DIMENSIONS</b>					
				inch	millimeter
<b>Gage Length</b>	<b>Overall Length</b>	<b>Grid Width</b>	<b>Overall Width</b>	<b>Matrix Length</b>	<b>Matrix Width</b>
0.051	0.262	0.051	0.206	0.30	0.25
1.30	6.64	1.30	5.23	7.6	6.3

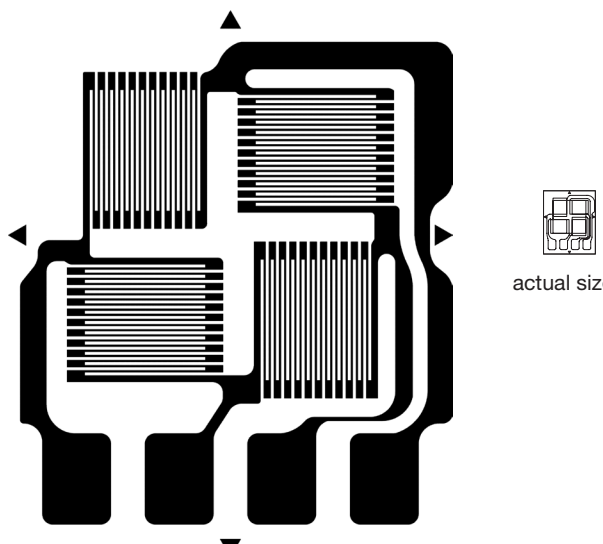

\* Only creep code available for this gage.

Transducer-Class® Strain Gages with Advanced Sensors Technology

S5193 GAGE PATTERN DATA			
 <p>actual size</p>	<b>GAGE DESIGNATION</b>  N2A-XX-S5193R-350/E5	<b>RESISTANCE IN OHMS</b>  350 ±3%	<b>STD. CREEP CODE</b>  R*
	<b>DESCRIPTION</b>  Full-bridge for bending-beam transducers. Bridge is balanced to ±0.5 mV/V, but RG is 350 Ω ±3%.		 <p><b>RoHS COMPLIANT</b></p>

GAGE DIMENSIONS					
				inch	millimeter
<b>Gage Length</b>	<b>Overall Length</b>	<b>Grid Width</b>	<b>Overall Width</b>	<b>Matrix Length</b>	<b>Matrix Width</b>
0.071	0.264	0.071	0.220	0.33	0.27
1.80	6.71	1.80	5.59	8.3	6.8

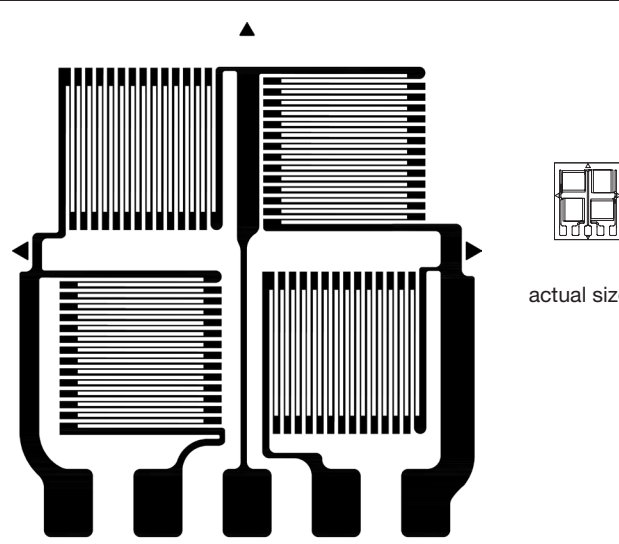

\* Only creep code available for this gage.

S5139 GAGE PATTERN DATA			
 <p>actual size</p>	<b>GAGE DESIGNATION</b>  N2A-XX-S5139U-350/E4	<b>RESISTANCE IN OHMS</b>  350 ±0.2%	<b>STD. CREEP CODE</b>  U*
	<b>DESCRIPTION</b>  Open full-bridge pattern for single-surface gaging of transducers.		 <p><b>RoHS COMPLIANT</b></p>

GAGE DIMENSIONS					
				inch	millimeter
<b>Gage Length</b>	<b>Overall Length</b>	<b>Grid Width</b>	<b>Overall Width</b>	<b>Matrix Length</b>	<b>Matrix Width</b>
0.093	0.345	0.120	0.299	0.40	0.35
2.36	8.77	3.06	7.60	10.3	9.0

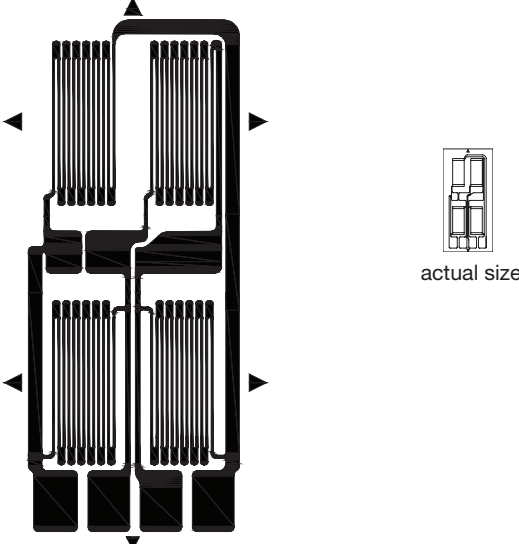

\* Only creep code available for this gage.

*Transducer-Class*® Strain Gages with Advanced Sensors Technology

<b>S5292 GAGE PATTERN DATA</b>			
 <p>actual size</p>	<b>GAGE DESIGNATION</b>	<b>RESISTANCE IN OHMS</b>	<b>STD. CREEP CODE</b>
	N2A-XX-S5292X-350/E5	350 ±3%	X*
<b>DESCRIPTION</b> Full-bridge pattern for use on double-bending beams. Axial grid centerline spacing 0.250 in (6.35 mm).			 <b>RoHS COMPLIANT</b>

<b>GAGE DIMENSIONS</b>						inch	millimeter
Gage Length	Overall Length	Grid Width	Overall Width	Matrix Length	Matrix Width		
0.125	0.455	0.060	0.192	0.54	0.26		
3.18	11.56	1.52	4.88	13.6	6.6		

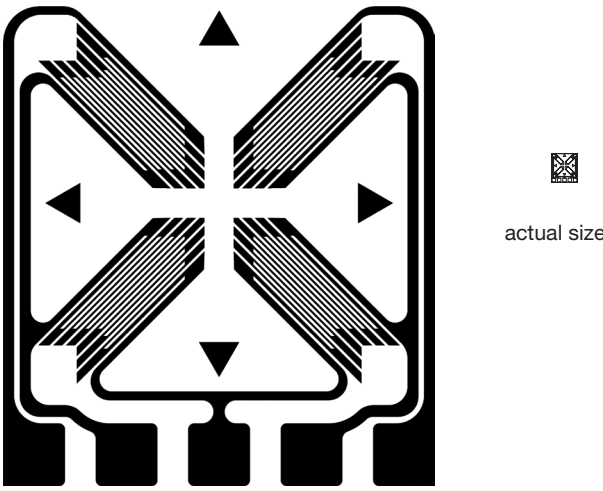

\* Only creep code available for this gage.

<b>S5023 GAGE PATTERN DATA</b>			
 <p>actual size</p>	<b>GAGE DESIGNATION</b>	<b>RESISTANCE IN OHMS</b>	<b>STD. CREEP CODE</b>
	N2K-XX-S5023M-10C/DG/E5 N5K-XX-S5023M-10C/DG/E5	1000 ±0.2% 1000 ±0.2%	M* M*
<b>DESCRIPTION</b> Full-bridge pattern for shear or torque transducers.			 <b>RoHS COMPLIANT</b>

<b>GAGE DIMENSIONS</b>						inch	millimeter
Gage Length	Overall Length	Grid Width	Overall Width	Matrix Length	Matrix Width		
0.045	0.160	0.024	0.144	0.17	0.15		
1.15	4.06	0.61	3.66	4.2	3.8		

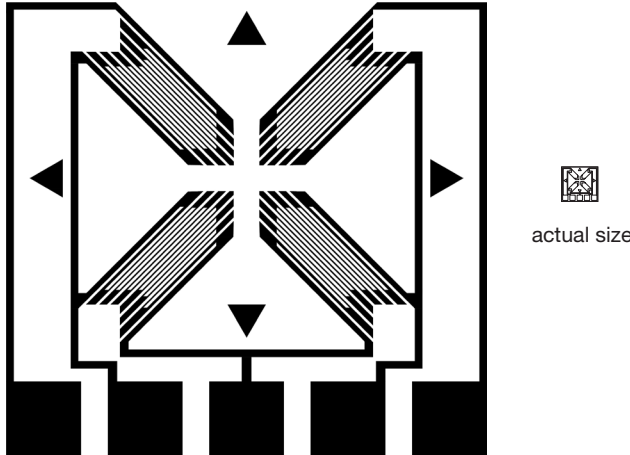

\* Only creep code available for this gage.  
Copper plating for tabs is available.

Transducer-Class® Strain Gages with Advanced Sensors Technology

S5046 GAGE PATTERN DATA			
 <p>actual size</p>	<b>GAGE DESIGNATION</b>	<b>RESISTANCE IN OHMS</b>	<b>STD. CREEP CODE</b>
	N2K-XX-S5046M-50C/DG/E5 N5K-XX-S5046M-50C/DG/E5	5000 ±0.2% 5000 ±0.2%	M* M*
<b>DESCRIPTION</b> Open full-bridge pattern for shear or torque transducers.			

GAGE DIMENSIONS					
				inch	millimeter
<b>Gage Length</b>	<b>Overall Length</b>	<b>Grid Width</b>	<b>Overall Width</b>	<b>Matrix Length</b>	<b>Matrix Width</b>
0.044	0.170	0.024	0.180	0.18	0.19
1.12	4.31	0.61	4.57	4.5	4.8

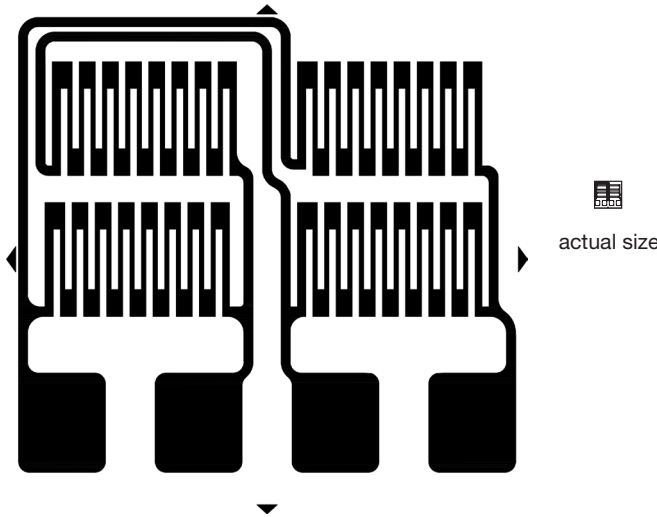
\* Only creep code available for this gage.  
Copper plating for tabs is available.



S5047 GAGE PATTERN DATA			
 <p>actual size</p>	<b>GAGE DESIGNATION</b>	<b>RESISTANCE IN OHMS</b>	<b>STD. CREEP CODE</b>
	N2K-XX-S5047K-10C/DG/E5 N5K-XX-S5047K-10C/DG/E5	1000 ±3% 1000 ±3%	K* K*
<b>DESCRIPTION</b> Compact full-bridge pattern for use on small, double-bending beams. Bridge is balanced to ±0.4 mV/V, but RG is 1000 Ω ±3%.			

GAGE DIMENSIONS					
				inch	millimeter
<b>Gage Length</b>	<b>Overall Length</b>	<b>Grid Width</b>	<b>Overall Width</b>	<b>Matrix Length</b>	<b>Matrix Width</b>
0.017	0.112	0.060	0.137	0.14	0.15
0.43	2.86	1.52	3.49	3.7	3.8

\* Only creep code available for this gage.  
Copper plating for tabs is available.

Transducer-Class® Strain Gages with Advanced Sensors Technology

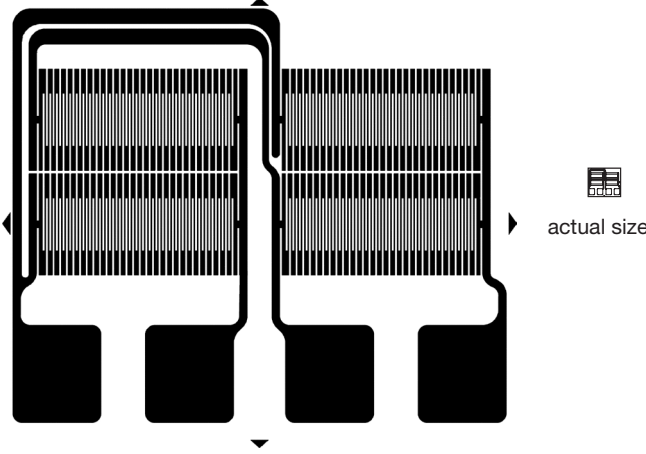

**S5072 GAGE PATTERN DATA**

 <p>actual size</p>	<p><b>GAGE DESIGNATION</b></p> <p>N2K-XX-S5072N-10C/DG/E5 N5K-XX-S5072N-10C/DG/E5</p>	<p><b>RESISTANCE IN OHMS</b></p> <p>1000 ±3% 1000 ±3%</p>	<p><b>STD. CREEP CODE</b></p> <p>N* N*</p>
	<p><b>DESCRIPTION</b></p> <p>Compact full-bridge pattern for use on small, double-bending beams. Bridge is balanced to 0.4 mV/V, but RG is 1000 Ω ±3%.</p>		 <p><b>RoHS COMPLIANT</b></p>

GAGE DIMENSIONS						inch	millimeter
Gage Length	Overall Length	Grid Width	Overall Width	Matrix Length	Matrix Width		
0.017	0.113	0.064	0.156	0.15	0.17		
0.43	2.86	1.63	3.97	3.7	4.2		

\* Only creep code available for this gage.  
Copper plating for tabs is available.

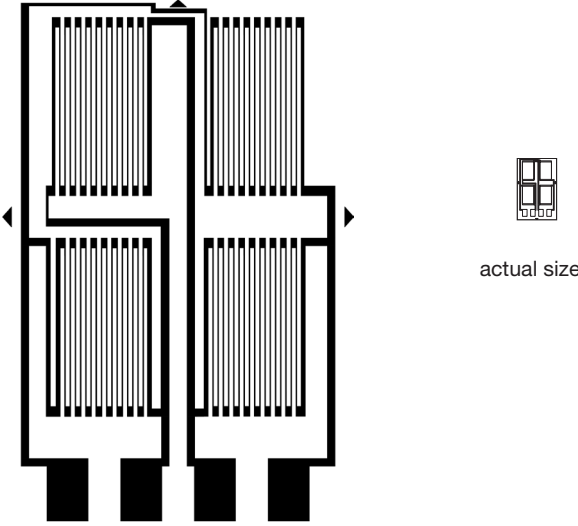
**S5051 GAGE PATTERN DATA**



 <p>actual size</p>	<p><b>GAGE DESIGNATION</b></p> <p>N2K-XX-S5051M-11C/DG/E5 N5K-XX-S5051M-11C/DG/E5</p>	<p><b>RESISTANCE IN OHMS</b></p> <p>1100 ±3% 1100 ±3%</p>	<p><b>STD. CREEP CODE</b></p> <p>M* M*</p>
	<p><b>DESCRIPTION</b></p> <p>Full-bridge pattern for double-bending beams. Bridge is balanced to ±0.3 mV/V, but RG is 1100 Ω ±3%.</p>		 <p><b>RoHS COMPLIANT</b></p>

GAGE DIMENSIONS						inch	millimeter
Gage Length	Overall Length	Grid Width	Overall Width	Matrix Length	Matrix Width		
0.118	0.376	0.079	0.196	0.42	0.27		
3.00	9.58	2.00	5.00	10.6	6.8		

\* Only creep code available for this gage.  
Copper plating for tabs is available.



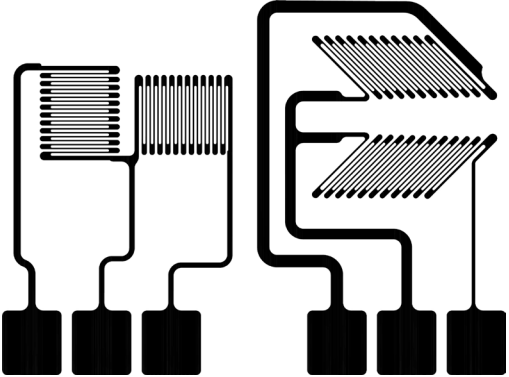

Transducer-Class® Strain Gages with Advanced Sensors Technology

S5060 GAGE PATTERN DATA			
 	GAGE DESIGNATION	RESISTANCE IN OHMS	STD. CREEP CODE
	N2K-XX-S5060-10C/DG/E5 N5K-XX-S5060-10C/DG/E5	1000 ±0.2% 1000 ±0.2%	K, N K, N
<b>DESCRIPTION</b> Half-bridge combination for use in pairs to construct two full-bridges for simultaneous measurement of torsion and axial load.			

GAGE DIMENSIONS					
				inch	millimeter
Gage Length	Overall Length	Grid Width	Overall Width	Matrix Length	Matrix Width
0.033	0.289	0.056	0.210	0.32	0.25
0.85	7.34	1.43	5.33	8.2	6.4

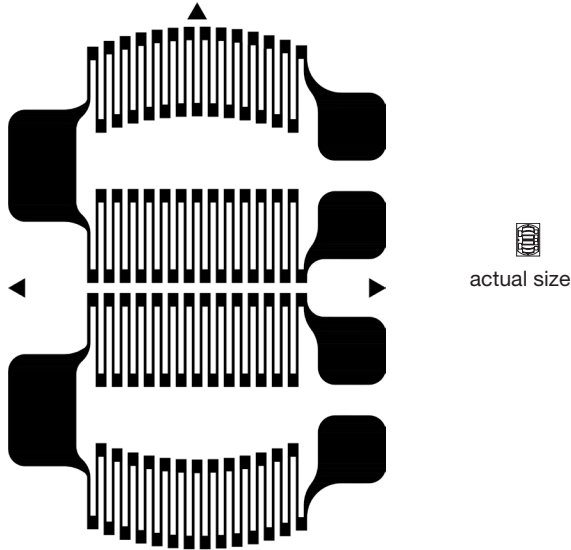

Copper plating for tabs is available.

**Transducer-Class® Strain Gages with Advanced Sensors Technology**

<b>S5206 GAGE PATTERN DATA</b>			
	<b>GAGE DESIGNATION</b>	<b>RESISTANCE IN OHMS</b>	<b>STD. CREEP CODE</b>
	N2K-XX-S5206F-50C/DG/E5 N5K-XX-S5206F-50C/DG/E5	5000 ±0.3% 5000 ±0.3%	F* F*
<b>DESCRIPTION</b> Full-bridge pattern for use on 0.174 in (4.42 mm) diameter diaphragm.			

<b>GAGE DIMENSIONS</b>					
				<b>inch</b>	<b>millimeter</b>
<b>Gage Length</b>	<b>Overall Length</b>	<b>Grid Width</b>	<b>Overall Width</b>	<b>Matrix Length</b>	<b>Matrix Width</b>
0.019	0.146	0.065	0.111	0.17	0.12
0.48	3.70	1.65	2.82	4.4	3.0

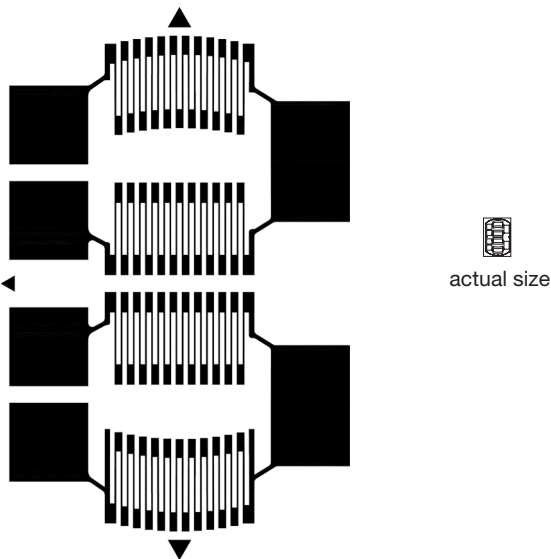

\* Only creep code available for this gage.  
Copper plating for tabs is available.

<b>GAGE PATTERN DATA</b>			
	<b>GAGE DESIGNATION</b>	<b>RESISTANCE IN OHMS</b>	<b>STD. CREEP CODE</b>
	N2K-XX-S5065M-350/DG/E5 N5K-XX-S5065M-350/DG/E5 N2K-XX-S5021M-50C/DG/E5 N5K-XX-S5021M-50C/DG/E5	350 ±0.3% 350 ±0.3% 5000 ±0.3% 5000 ±0.3%	M* M* M* M*
<b>DESCRIPTION</b> Full-bridge pattern for use on 0.200 in (5.080 mm) diameter diaphragm.			

<b>GAGE DIMENSIONS</b>					
				<b>inch</b>	<b>millimeter</b>
<b>Gage Length</b>	<b>Overall Length</b>	<b>Grid Width</b>	<b>Overall Width</b>	<b>Matrix Length</b>	<b>Matrix Width</b>
0.019	0.168	0.059	0.117	0.20	0.13
0.49	4.27	1.50	2.96	5.1	3.2

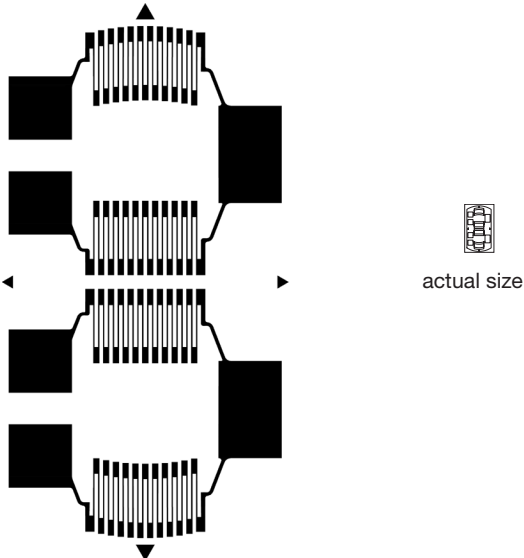

\* Only creep code available for this gage.  
Copper plating for tabs is available.

Transducer-Class® Strain Gages with Advanced Sensors Technology

GAGE PATTERN DATA			
	GAGE DESIGNATION	RESISTANCE IN OHMS	STD. CREEP CODE
	N2K-XX-S5066M-350/DG/E5	350 ±0.3%	M*
	N5K-XX-S5066M-350/DG/E5	350 ±0.3%	M*
	N2K-XX-S5022M-50C/DG/E5	5000 ±0.3%	M*
	N5K-XX-S5022M-50C/DG/E5	5000 ±0.3%	M*
<b>DESCRIPTION</b> Full-bridge pattern for use on 0.250 in (6.35 mm) diameter diaphragm.			 <b>RoHS</b> COMPLIANT

GAGE DIMENSIONS					
				inch	millimeter
Gage Length	Overall Length	Grid Width	Overall Width	Matrix Length	Matrix Width
0.020	0.212	0.050	0.112	0.25	0.12
0.51	5.38	1.27	2.84	6.4	3.1

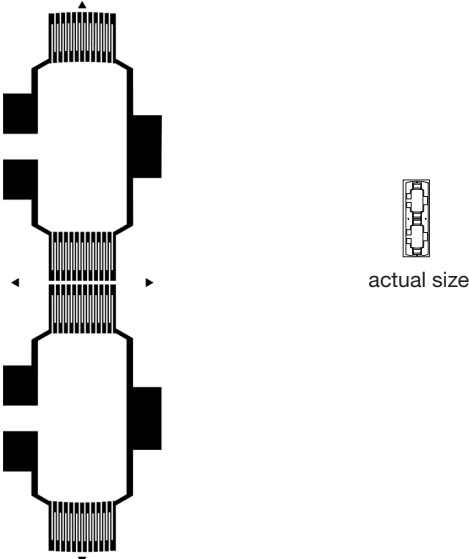

\* Only creep code available for this gage.  
Copper plating for tabs is available.

S5026 GAGE PATTERN DATA			
	GAGE DESIGNATION	RESISTANCE IN OHMS	STD. CREEP CODE
	N2K-XX-S5026M-50C/DG/E5	5000 ±0.3%	M*
	N5K-XX-S5026M-50C/DG/E5	5000 ±0.3%	M*
<b>DESCRIPTION</b> Full bridge pattern for use on 0.400 in (10.16 mm) diameter diaphragm.			 <b>RoHS</b> COMPLIANT

GAGE DIMENSIONS					
				inch	millimeter
Gage Length	Overall Length	Grid Width	Overall Width	Matrix Length	Matrix Width
0.020	0.368	0.044	0.111	0.40	0.12
0.51	9.35	1.12	2.82	10.2	3.1

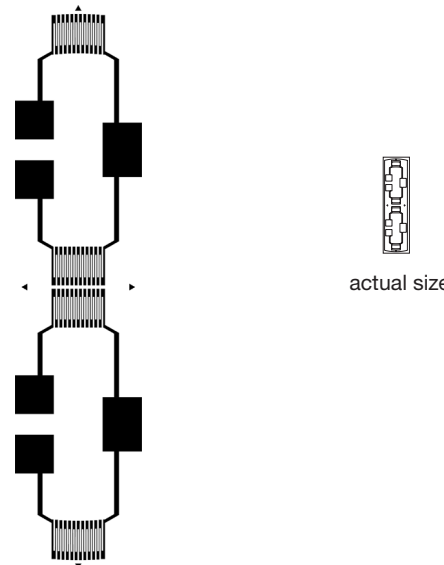

\* Only creep code available for this gage.  
Copper plating for tabs is available.

Transducer-Class® Strain Gages with Advanced Sensors Technology

<b>S5025 GAGE PATTERN DATA</b>			
 <p>actual size</p>	<b>GAGE DESIGNATION</b>	<b>RESISTANCE IN OHMS</b>	<b>STD. CREEP CODE</b>
	N2K-XX-S5025M-50C/DG/E5 N5K-XX-S5025M-50C/DG/E5	5000 ±0.3% 5000 ±0.3%	M* M*
<b>DESCRIPTION</b> Full-bridge pattern for use on 0.500 in (12.7 mm) diameter diaphragm.			

<b>GAGE DIMENSIONS</b>					
				inch	millimeter
<b>Gage Length</b>	<b>Overall Length</b>	<b>Grid Width</b>	<b>Overall Width</b>	<b>Matrix Length</b>	<b>Matrix Width</b>
0.020	0.483	0.047	0.111	0.50	0.12
0.51	12.26	1.19	2.82	12.7	3.1

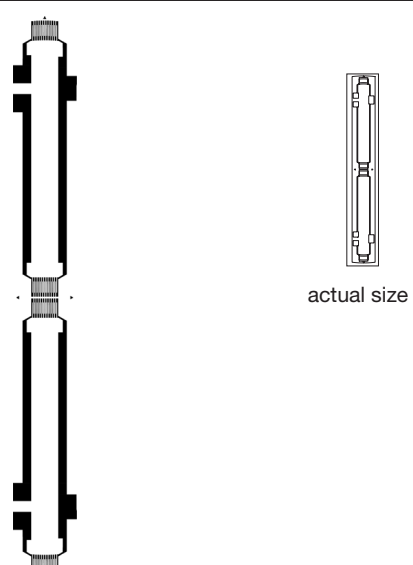

\* Only creep code available for this gage.  
Copper plating for tabs is available.

<b>S5071 GAGE PATTERN DATA</b>			
 <p>actual size</p>	<b>GAGE DESIGNATION</b>	<b>RESISTANCE IN OHMS</b>	<b>STD. CREEP CODE</b>
	N2K-XX-S5071M-50C/DG/E5 N5K-XX-S5071M-50C/DG/E5	5000 ±0.3% 5000 ±0.3%	M* M*
<b>DESCRIPTION</b> Full-bridge pattern for use on 1.00 in (25.4 mm) diameter diaphragm.			

<b>GAGE DIMENSIONS</b>					
				inch	millimeter
<b>Gage Length</b>	<b>Overall Length</b>	<b>Grid Width</b>	<b>Overall Width</b>	<b>Matrix Length</b>	<b>Matrix Width</b>
0.020	0.968	0.047	0.111	1.00	0.12
0.51	24.59	1.19	2.82	25.4	3.1

\* Only creep code available for this gage.  
Copper plating for tabs is available.

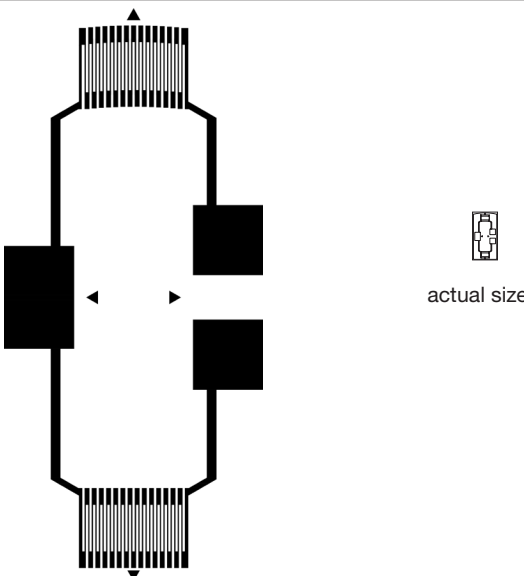

Transducer-Class® Strain Gages with Advanced Sensors Technology

<b>S5050 GAGE PATTERN DATA</b>			
	<b>GAGE DESIGNATION</b>	<b>RESISTANCE IN OHMS</b>	<b>STD. CREEP CODE</b>
	N2K-XX-S5050M-30C/DG/E5 N5K-XX-S5050M-30C/DG/E5	3000 ±0.3% 3000 ±0.3%	M* M*
<b>DESCRIPTION</b> Half-bridge diaphragm configuration.			

<b>GAGE DIMENSIONS</b>					
				inch	millimeter
Gage Length	Overall Length	Grid Width	Overall Width	Matrix Length	Matrix Width
0.020	0.217	0.047	0.111	0.25	0.13
0.51	5.52	1.19	2.82	6.4	3.2

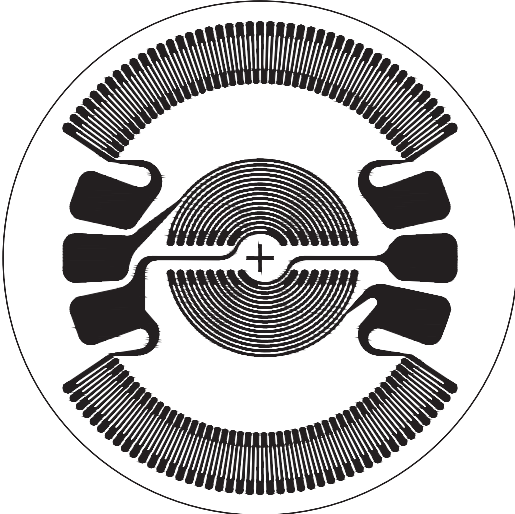

\* Only creep code available for this gage.  
Copper plating for tabs is available.

**Transducer-Class® Strain Gages with Advanced Sensors Technology**

<b>S5294 GAGE PATTERN DATA</b>			
	<b>GAGE DESIGNATION</b>	<b>RESISTANCE IN OHMS</b>	<b>STD. CREEP CODE</b>
	N2K-XX-S5294R-350/DP/E4 N5K-XX-S5294R-350/DP/E4	350 ±0.2% 350 ±0.2%	R* R*
<b>DESCRIPTION</b> Full-bridge pattern for use on 0.250 in (6.35 mm) diameter diaphragm			 <b>RoHS</b> COMPLIANT

<b>GAGE DIMENSIONS</b>			
		inch	millimeter
<b>Pattern Diameter</b>	<b>Circular Trim Diameter</b>	<b>Outer G.L.</b>	<b>Inner G.L.</b>
0.218	0.250	0.018	0.037
5.52	6.35	0.44	0.95

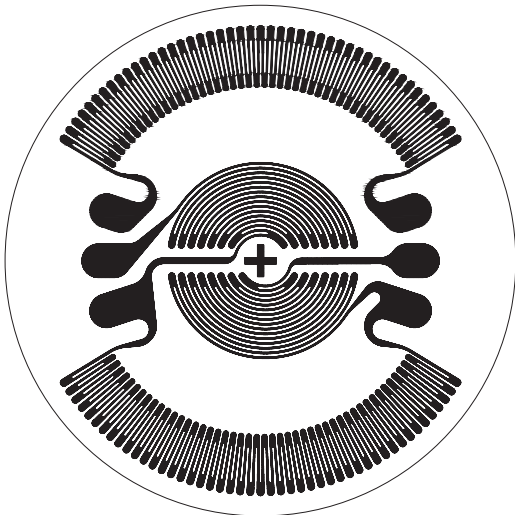

\* Only creep code available for this gage.  
Copper plating for tabs is available.

<b>S5214 GAGE PATTERN DATA</b>			
	<b>GAGE DESIGNATION</b>	<b>RESISTANCE IN OHMS</b>	<b>STD. CREEP CODE</b>
	N2A-XX-S5214R-350/E5	350 ±0.2%	R*
<b>DESCRIPTION</b> Full-bridge pattern for use on 0.400 in (10.16 mm) diameter diaphragm.			 <b>RoHS</b> COMPLIANT

<b>GAGE DIMENSIONS</b>			
		inch	millimeter
<b>Pattern Diameter</b>	<b>Circular Trim Diameter</b>	<b>Outer G.L.</b>	<b>Inner G.L.</b>
0.368	0.400	0.028	0.063
9.34	10.16	0.71	1.59

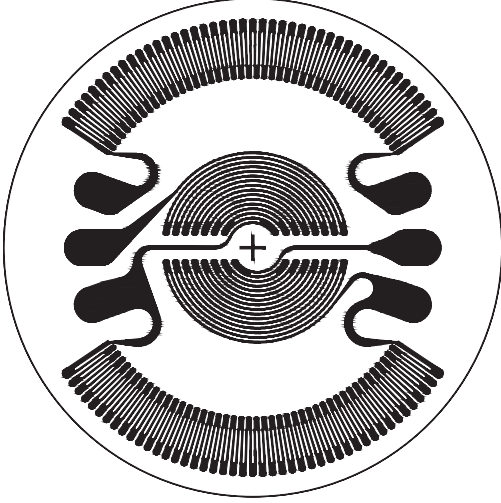

\* Only creep code available for this gage.

Transducer-Class® Strain Gages with Advanced Sensors Technology

<b>S5374 GAGE PATTERN DATA</b>			
	<b>GAGE DESIGNATION</b>	<b>RESISTANCE IN OHMS</b>	<b>STD. CREEP CODE</b>
	N2K-XX-S5374R-350/DP/E4 N5K-XX-S5374R-350/DP/E4	350 ±0.2% 350 ±0.2%	R* R*
<b>DESCRIPTION</b> Full-bridge pattern for use on 0.500 in (12.70 mm) diameter diaphragm.			

<b>GAGE DIMENSIONS</b>			
		inch	millimeter
<b>Pattern Diameter</b>	<b>Circular Trim Diameter</b>	<b>Outer G.L.</b>	<b>Inner G.L.</b>
0.436	0.500	0.035	0.065
11.04	12.70	0.88	1.65

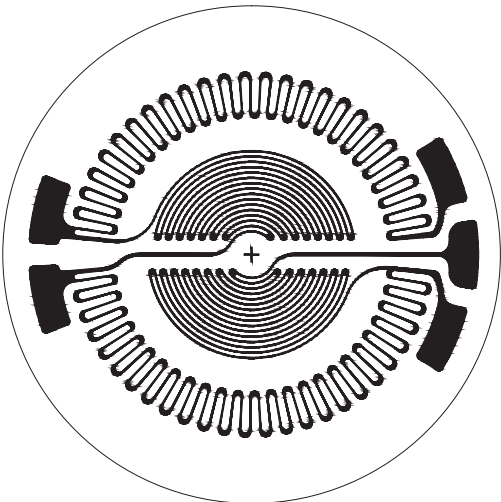
\* Only creep code available for this gage.  
Copper plating for tabs is available.

<b>S5213 GAGE PATTERN DATA</b>			
	<b>GAGE DESIGNATION</b>	<b>RESISTANCE IN OHMS</b>	<b>STD. CREEP CODE</b>
	N2K-XX-S5213D-35C/DG/E5 N5K-XX-S5213D-35C/DG/E5	3500 ±1% 3500 ±1%	D* D*
<b>DESCRIPTION</b> Full-bridge pattern for use on 0.670 in (17.02 mm) diameter diaphragm.			

<b>GAGE DIMENSIONS</b>			
		inch	millimeter
<b>Pattern Diameter</b>	<b>Circular Trim Diameter</b>	<b>Outer G.L.</b>	<b>Inner G.L.</b>
0.240	0.670	0.025	0.057
6.10	17.02	0.64	1.46

\* Only creep code available for this gage.  
Copper plating for tabs is available.

**Bondable Resistors for Transducers – Selection Chart**

**N2B Balco** resistors are available in our LT02 and LT06 sizes.

**N2T Nickel** resistors are available in our LT02, LT06, LT09 and LT10 sizes. The standard resistance values for each are as shown. Custom resistance values are available for a small set-up charge and 500-piece minimum order.

Resistance tolerance is  $\pm 1\%$  at  $+75^\circ\text{F}$  ( $+24^\circ\text{C}$ ).

Recommended Uses:

- span-shift-versus-temperature compensation
- temperature sensing





**Construction**

Fixed pattern resistors are normally manufactured and stocked with E5 encapsulation as standard. Solder tabs are left exposed for leadwire connections.

**Examples:**

N2B-TR-LT06-00200/E5, N2T-TR-LT02-00250/E5.

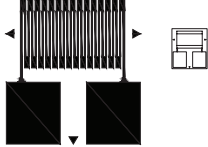
Resistance tolerance on Option E5 versions is  $\pm 1\%$  at  $+75^\circ\text{F}$  ( $+24^\circ\text{C}$ ).

GAGE PATTERN AND DESIGNATION Matrix is shown at actual size. Insert Desired Resistors Size in Spaces Marked XX.		STANDARD RESISTANCE RANGE IN OHMS	DIMENSIONS																			
			PATTERN		MATRIX																	
			Length	Width	Length	Width																
<p><b>LT02</b></p>  <p><b>LT06</b></p> 	<p><b>Nickel options:</b> N2T-TR-LTXX-00150 N2T-TR-LTXX-00175 N2T-TR-LTXX-00200 N2T-TR-LTXX-00250 N2T-TR-LTXX-00300 N2T-TR-LTXX-00400 N2T-TR-LTXX-00600 N2T-TR-LTXX-00650 N2T-TR-LTXX-00700</p> <p><b>Balco options:</b> N2B-TR-LTXX-00150 N2B-TR-LTXX-00175 N2B-TR-LTXX-00200 N2B-TR-LTXX-00250 N2B-TR-LTXX-00300 N2B-TR-LTXX-00400 N2B-TR-LTXX-00600 N2B-TR-LTXX-00650 N2B-TR-LTXX-00700</p>	15	<p><b>LT02</b></p> <table border="1"> <tr><td>0.24</td><td>0.13</td><td>0.30</td><td>0.19</td></tr> <tr><td>6.1</td><td>3.2</td><td>7.5</td><td>4.7</td></tr> </table> <p><b>LT06</b></p> <table border="1"> <tr><td>0.19</td><td>0.13</td><td>0.24</td><td>0.18</td></tr> <tr><td>4.8</td><td>3.3</td><td>6.1</td><td>4.6</td></tr> </table> <p>RoHS compliant.</p>				0.24	0.13	0.30	0.19	6.1	3.2	7.5	4.7	0.19	0.13	0.24	0.18	4.8	3.3	6.1	4.6
		0.24					0.13	0.30	0.19													
		6.1					3.2	7.5	4.7													
		0.19					0.13	0.24	0.18													
		4.8					3.3	6.1	4.6													
		17.5																				
		20																				
		25																				
		30																				
		40																				
60																						
65																						
70																						
<p><b>LT09</b></p>  <p><b>LT10</b></p> 	<p><b>Nickel options:</b> N2T-TR-LTXX-00100 N2T-TR-LTXX-00125 N2T-TR-LTXX-00150 N2T-TR-LTXX-00200 N2T-TR-LTXX-00225 N2T-TR-LTXX-00300 N2T-TR-LTXX-00400 N2T-TR-LTXX-00450 N2T-TR-LTXX-00500 N2T-TR-LTXX-00600 N2T-TR-LTXX-00720 N2T-TR-LTXX-00800 N2T-TR-LTXX-00900</p>	10	<p><b>LT09</b></p> <table border="1"> <tr><td>0.12</td><td>0.11</td><td>0.13</td><td>0.12</td></tr> <tr><td>3.0</td><td>2.7</td><td>3.3</td><td>3.0</td></tr> </table> <p><b>LT10</b></p> <table border="1"> <tr><td>0.08</td><td>0.07</td><td>0.09</td><td>0.07</td></tr> <tr><td>2.1</td><td>1.8</td><td>2.5</td><td>1.9</td></tr> </table> <p>RoHS compliant.</p>				0.12	0.11	0.13	0.12	3.0	2.7	3.3	3.0	0.08	0.07	0.09	0.07	2.1	1.8	2.5	1.9
		0.12					0.11	0.13	0.12													
		3.0					2.7	3.3	3.0													
		0.08					0.07	0.09	0.07													
		2.1					1.8	2.5	1.9													
		12.5																				
		15																				
		20																				
		22.5																				
		30																				
40																						
45																						
50																						
60																						
72																						
80																						
90																						



## Bondable Resistors for Transducers – Selection Chart

GAGE PATTERN AND DESIGNATION Actual size shown on right Insert Desired S-T-C No. in Spaces Marked XX. See Note 1	RESISTANCE IN OHMS		DIMENSIONS			
			PATTERN		MATRIX	
			Length	Width	Length	Width
 N2B-TR-C11-00050 N2B-TR-C12-00100 N2B-TR-C12-00200 N2B-TR-C13-00400 N2B-TR-C13-00800	Before Cut 5 10 20 40 80	After Cut 12 24 48 96 192	0.30	0.20	0.34	0.23
			7.6	5.1	8.6	5.9
 N2F-TR-D01-00005 N2B-TR-D01-00060 N2A-XX-D01-00180 EA-XX-D01-00360 N2K-XX-D01-00500/DP N2K-XX-D01-00750/DP	0.5 6 18 36 50 75		0.35	0.14	0.41	0.20
			8.9	3.6	10.4	5.1
 N2F-TR-E01-00005 N2A-XX-E01-00060 N2A-XX-E01-00180 EA-XX-E01-00360 N2K-XX-E01-00500/DP N2K-XX-E01-00750/DP	0.5 6 18 36 50 75		0.35	0.30	0.41	0.36
			8.9	7.6	10.4	9.1
 N2A-XX-H21-00025 N2A-XX-H21-00060 N2B-TR-H22-00010	2.5 6.0 1.0		0.15	0.29	0.21	3.5
			3.8	7.4	5.3	8.9

### RESISTANCE WIRE

While wire does not track the temperature of the strain gages as closely as bondable resistors, there are instances where bondable resistors cannot be used due to limited mounting space. Micro-Measurements stocks two types of resistance wire alloys.

CATALOG NO./ WIRE ALLOY	QTY PER SPOOL	RESISTANCE PER FT (M) NOMINAL	TCR [-10° TO +50°C]	INSULATION	TEMPERATURE RANGE
137-HWN/Manganin	200 ft [61m]	14Ω (46Ω)	± 0.0011%/°F [± 0.002%/°C]	Enamel	+15° to +120°F [-10° to +50°C] (up to +175°F [+80°C] if proper aging is done)
142-JWN/Balco	500 ft [152m]	19Ω (62Ω)	+0.25%/°F [+0.45%/°C]	Enamel	-15° to +300°F [-10° to +150°C]

**NOTE 1:** All products are RoHS compliant.





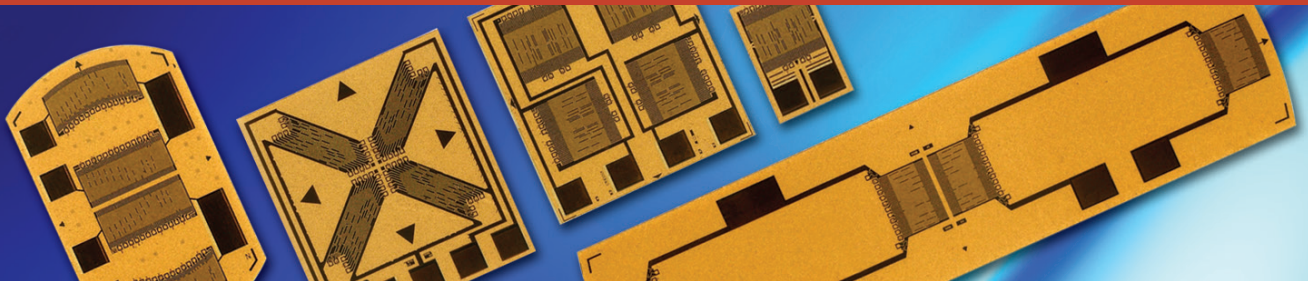

Contact

[mm@vpgsensors.com](mailto:mm@vpgsensors.com)

[micro-measurements.com](http://micro-measurements.com)