

"U" GAGE SCHEMATIC

See Table for X, Y & Z dimensions

X=Overall Length
Y= Active Area
Z= Width

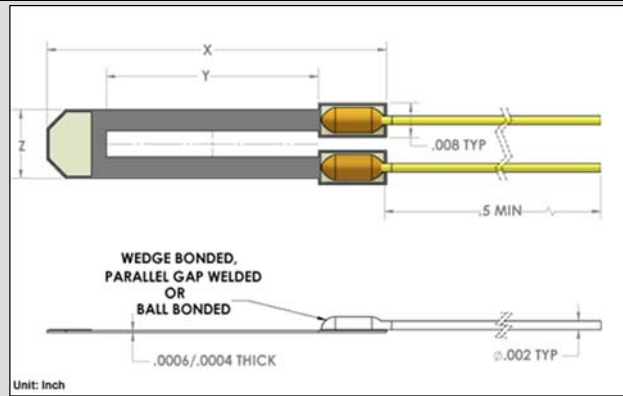

"U" SHAPED GAGE

Part Number X Y	Z	Lead Attachment	Thickness	Resistance Ohms @ 78°F	Gage Factor	TCGF	TCR
SS-018-011-3000PU	0.012	Ball Bond	0.0004	3000 ± 150	100 ± 10	-23%	42%
SS-037-022-500PU	0.016	Welded	0.0004	540 ± 50	150 ± 10	-13%	17%
SS-047-025-350PU	0.016	Welded	0.0004	325 ± 40	100 ± 10	-10%	6%
SS-047-025-500PU	0.016	Welded	0.0004	540 ± 50	140 ± 10	-13%	16%
SS-047-025-1000PU	0.016	Welded	0.0004	1000 ± 100	160 ± 10	-20%	28%
SS-060-033-300PU	0.016	Welded	0.0004	325 ± 40	100 ± 10	-10%	6%
SS-060-033-500PU	0.016	Welded	0.0004	540 ± 50	140 ± 10	-12%	14%
SS-060-033-2000PU	0.016	Welded	0.0004	2000 ± 100	155 ± 10	-18%	24%
SS-080-050-10000PU	0.013	Welded	0.0004	10000 ± 1000	175 ± 10	-23%	42%
SS-095-060-350PU	0.016	Welded	0.0004	350 ± 50	120 ± 10	-9%	5%

"M" GAGE SCHEMATIC

See Table for X, Y & Z dimensions

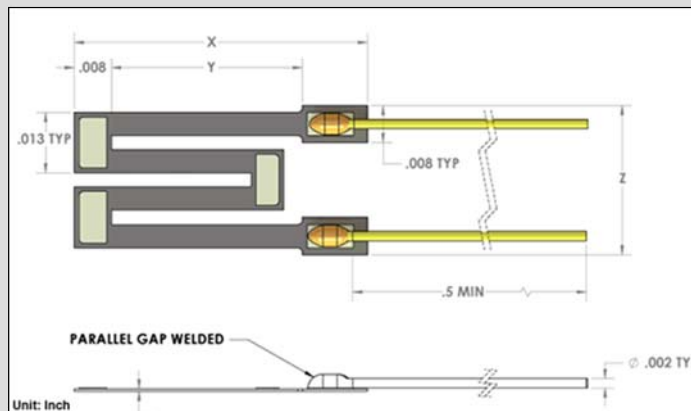
X=Overall Length
Y= Active Area
Z= Width

"M" SHAPED GAGE

Part Number X Y	Z	Lead Attachment	Thickness	Resistance Ohms @ 78°F	Gage Factor	TCGF	TCR
SS-060-040-2500PM	0.032	Welded	0.004	2500 ± 150	140 ± 10	-13%	17%

"U" Semiconductor Strain Gage Pricing Information										
Part No. ▼ Quantity ▶	1-4	5-9	10-24	25-49	50-99	100-150	151-300	301-500	501-1000	1001-2000
SS-018-011-3000PU-S1	\$12.16	\$10.95	\$10.79	\$8.95	\$8.58	\$8.39	Call for Price	Call for Price	Call for Price	Call for Price
SS-018-011-3000PU-S2	\$45.55	\$35.43	\$28.22	\$19.05	\$18.79	\$17.33	Call for Price	Call for Price	Call for Price	Call for Price
SS-018-011-3000PU-S4	\$95.00	\$80.00	\$65.00	\$45.00	\$41.00	\$39.00	37.00	Call for Price	Call for Price	Call for Price
SS-037-022-500PU-S1	\$11.47	\$10.36	\$9.57	\$7.72	\$6.48	\$6.38	\$6.02	\$5.40	\$5.11	Call for Price
2	\$42.99	\$33.52	\$25.04	\$17.15	\$13.62	\$13.16	\$12.57	\$11.39	\$10.92	Call for Price
4	\$89.66	\$75.69	\$57.64	\$40.47	\$29.69	\$29.61	\$28.60	\$27.74	\$26.87	Call for Price
SS-047-025-500PU-S1	\$11.47	\$10.36	\$9.57	\$7.72	\$6.48	\$6.38	\$6.02	\$5.40	\$5.11	Call for Price
2	\$42.99	\$33.52	\$25.04	\$17.15	\$13.62	\$13.16	\$12.57	\$11.39	\$10.92	Call for Price
4	\$89.66	\$75.69	\$57.64	\$40.47	\$35.04	\$29.62	\$28.61	\$27.74	\$26.87	Call for Price
SS-047-025-1000PU-S1	\$10.70	\$10.20	\$9.67	\$8.42	\$7.29	\$6.91	\$6.67	\$6.14	\$5.93	Call for Price
2	\$44.21	\$35.99	\$28.85	\$20.23	\$15.49	\$14.48	\$13.97	\$12.81	\$12.36	Call for Price
4	\$89.66	\$73.15	\$58.88	\$41.74	\$32.27	\$31.59	\$30.86	\$29.96	\$28.95	Call for Price
SS-060-033-300PU-S1	\$9.76	\$9.25	\$8.72	\$7.90	\$6.66	\$6.50	\$6.25	\$6.14	\$5.93	Call for Price
2	\$44.21	\$34.75	\$27.60	\$17.71	\$14.21	\$13.88	\$13.31	\$12.88	\$12.48	Call for Price
4	\$89.66	\$70.69	\$56.38	\$36.69	\$29.69	\$28.32	\$26.48	\$25.69	\$24.84	Call for Price
SS-060-033-500PU-S1	\$9.76	\$9.71	\$9.15	\$8.28	\$6.99	\$6.82	\$6.25	\$6.44	\$5.93	Call for Price
2	\$46.42	\$34.75	\$27.60	\$18.61	\$14.93	\$13.97	\$13.88	\$13.52	\$12.48	Call for Price
4	\$94.14	\$74.21	\$59.20	\$38.52	\$31.19	\$29.72	\$26.97	\$26.48	\$26.09	Call for Price
SS-060-033-2000PU-S1	\$10.70	\$10.20	\$9.67	\$8.42	\$7.29	\$6.91	\$6.67	\$6.14	\$5.93	Call for Price
2	\$44.21	\$35.99	\$28.85	\$20.23	\$15.49	\$14.48	\$13.97	\$12.81	\$12.36	Call for Price
4	\$89.66	\$73.15	\$58.88	\$41.74	\$32.27	\$31.59	\$30.86	\$29.96	\$28.95	Call for Price
SS-080-050-10000PU-S1	\$10.98	\$10.47	\$9.95	\$9.42	\$8.97	\$7.84	\$7.69	\$7.10	\$6.49	Call for Price
2	\$46.50	37.49	31.02	22.43	17.00	15.48	15.31	14.16	13.21	
4	92.01	75.09	60.91	44.05	34.44	33.95	32.97	31.95	30.00	
SS-095-060-350PU-S1	\$9.76	\$9.71	\$9.15	\$8.28	\$6.99	\$6.82	\$6.25	\$6.44	\$5.93	Call for Price
2	\$46.42	\$34.75	\$27.60	\$18.61	\$14.93	\$13.97	\$13.88	\$13.52	\$12.48	Call for Price
4	\$94.14	\$74.21	\$59.20	\$38.52	\$31.19	\$29.72	\$26.97	\$26.48	\$26.09	Call for Price

"M" Semiconductor Strain Gage Pricing Information										
Part No. ▼ Quantity ▶	1-4	5-9	10-24	25-49	50-99	100-150	151-300	301-500	501-1000	1001-2000
SS-060-040-2500PM-S1	\$16.54	\$13.37	\$11.25	\$10.22	\$9.26	\$8.56	\$7.22	\$6.14	\$5.50	Call for Price
2	\$46.67	\$40.94	\$37.60	\$29.13	\$23.21	\$18.41	\$15.43	\$14.85	\$12.61	Call for Price
4	\$94.55	\$83.11	\$76.42	\$59.44	\$47.69	\$38.14	\$32.13	\$28.54	\$27.00	Call for Price

STANDARD SEMICONDUCTOR STRAIN GAGES

Micron semiconductor strain gages are made from "P" doped bulk silicon. This is a two terminal resistive device. The silicon is micro machined to shape thus eliminating molecular dislocation or cracks, thereby optimizing performance.

STANDARD GAGE SPECIFICATIONS

Materials	Czochralski pulled boron doped silicon
Leads	.002 dia. Gold x 0.5 in. long. Some gages have .0015 dia. Leads.
Contact Pads	Gold nickel fused, vapor deposited gold or vapor deposited aluminum for Hi-Temp
Lead Attachments	Parallel gap welded with epoxy reinforcement. Ball Bond or Wedge Bond
Operating Strain	±2000 μ inch/inch (3000 μ inch/inch max.)
Linearity	Better than ±0.25% to 600 μ inch/inch Better than ±1.5% to 1500 μ inch/inch
Max. Operating Temperature	500°F

Ordering Guidelines **Example**

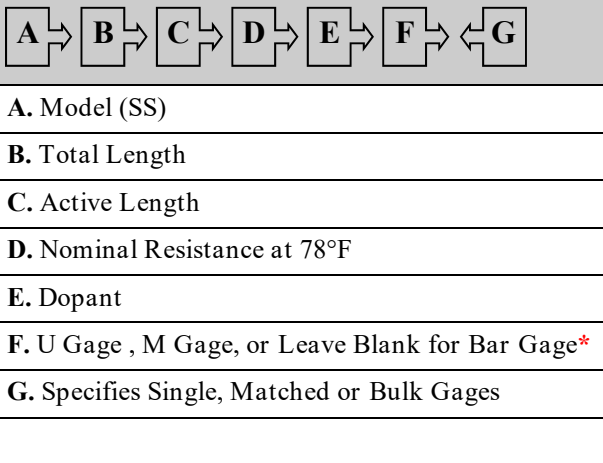

SS → **080** → **050** → **500** → **P** → **U** → **S4**

SS-080-050-500P U S4 is a Semiconductor Strain gage with a total length of **080** and an active length of **050**. The gage has a nominal resistance of **500** at 78 degrees F. The gage is further defined as Dopant **P** and Configured as a "**U**"* Gage. **S4** specifies a matched set of 4 gages.

Note:

- S4 Matched set of 4 gages
- S2 Matched set of 2 gages.
- S1 Single gage with data.
- S0 Bulk gage without data.

*Specify Gage Type: "U", "M" or Leave Blank for Bar Gage.
For Matched Sets of S5 up to sets of S16 Consult Factory

Standard Bridge Matching

Temperature °F	0°	78°	278°	
Standard Matching	±0.6%	±0.4%	±0.4%	Percent of Base Resistance

Note: Custom special matching gages (Mil-Spec.) or additional data points are also available. Please contact Micron Instruments for details. **Phone: (805) 522-4676**

Terms & Conditions

Min. Order: \$50.00

FOB: Simi Valley, California

Terms: Net 30 Days
Credit Cards: Visa, Master Card, American Express

Effective Date: 01-2016

Prices Subject to Change without Notice

PROPERTY OF MICRON INSTRUMENTS (805) 522-4676

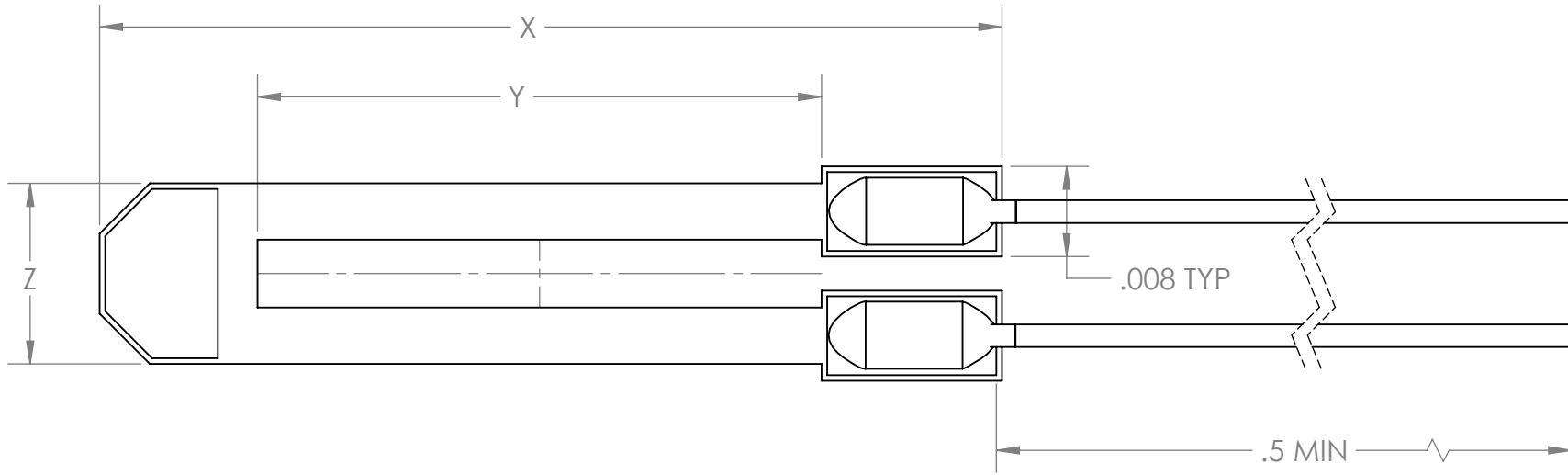

WEDGE BONDED,
PARALLEL GAP WELDED
OR
BALL BONDED

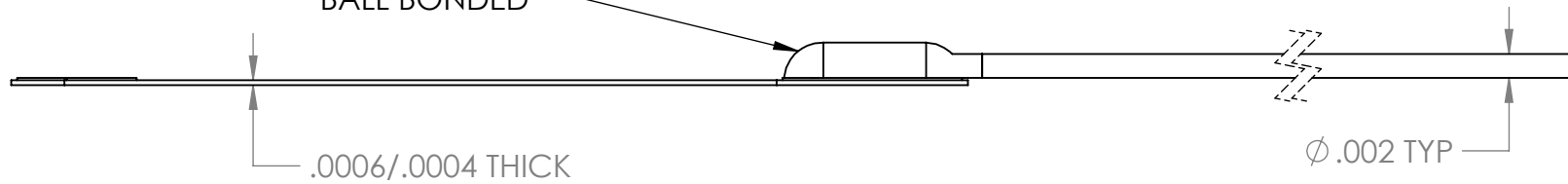

PROPRIETARY AND CONFIDENTIAL
THE INFORMATION CONTAINED IN THIS DRAWING IS THE SOLE PROPERTY OF MICRON INSTRUMENTS. REPRODUCTION IN PART OR AS A WHOLE WITHOUT THE WRITTEN PERMISSION OF MICRON INSTRUMENTS IS PROHIBITED.

		UNLESS OTHERWISE SPECIFIED:	NAME	DATE
		DIMENSIONS ARE IN INCHES	DRAWN	x
		TOLERANCES:	CHECKED	09/09/13
		ANGULAR: MACH ± 0° 30	ENG APPR.	
		ONE PLACE DECIMAL ± .030	MFG APPR.	
		TWO PLACE DECIMAL ± .010	Q.A.	
		THREE PLACE DECIMAL ± .005	COMPANY:	
		ALL DIA .005 TIR, RADII .005 MAX		
		SURFACE FINISH $\sqrt{32}$		
		INTERPRET GEOMETRIC TOLERANCING PER:		
		MATERIAL		
		FINISH		
NEXT ASSY	USED ON			
APPLICATION		DO NOT SCALE DRAWING		

MICRON INSTRUMENTS
4509 RUNWAY STREET
SIMI VALLEY, CA. 93063
(805) 522-4676 FAX (805) 522-4982
e-mail sensors@microninstruments.com

TITLE: **U-GAGE**

SIZE A	DWG. NO. MI-WEB	REV -
SCALE: 32:1	WEIGHT:	SHEET 1 OF 1

PROPERTY OF MICRON INSTRUMENTS (805) 522-4676

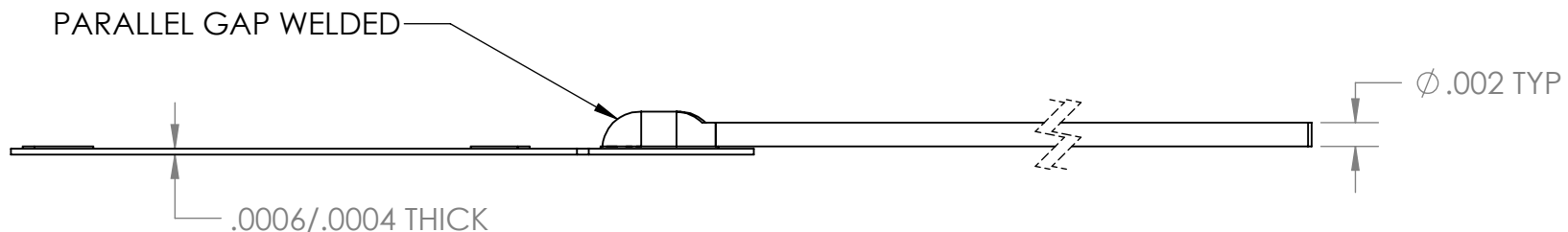
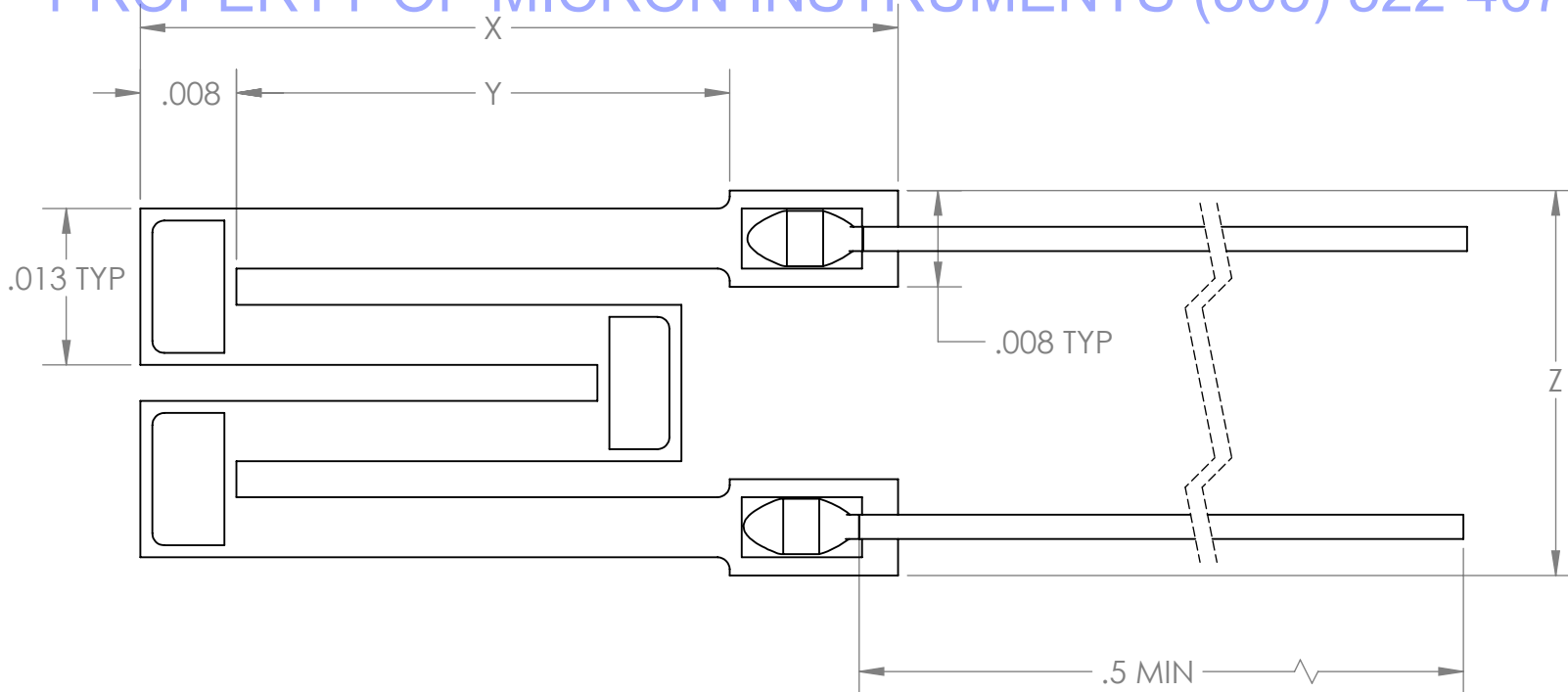

PROPRIETARY AND CONFIDENTIAL
 THE INFORMATION CONTAINED IN THIS DRAWING IS THE SOLE PROPERTY OF MICRON INSTRUMENTS. REPRODUCTION IN PART OR AS A WHOLE WITHOUT THE WRITTEN PERMISSION OF MICRON INSTRUMENTS IS PROHIBITED.

		UNLESS OTHERWISE SPECIFIED:	NAME	DATE
		DIMENSIONS ARE IN INCHES	DRAWN	x
		TOLERANCES:	CHECKED	09/09/13
		ANGULAR: MACH $\pm 0^\circ 30'$	ENG APPR.	
		ONE PLACE DECIMAL $\pm .030$	MFG APPR.	
		TWO PLACE DECIMAL $\pm .010$	Q.A.	
		THREE PLACE DECIMAL $\pm .005$	COMPANY:	
		ALL DIA .005 TIR, RADII .005 MAX		
		SURFACE FINISH $\sqrt{32}$		
		INTERPRET GEOMETRIC TOLERANCING PER:		
		MATERIAL		
NEXT ASSY	USED ON	FINISH		
APPLICATION		DO NOT SCALE DRAWING		

MICRON INSTRUMENTS

4509 RUNWAY STREET
 SIMI VALLEY, CA. 93063
 (805) 522-4676 FAX (805) 522-4982
 e-mail sensors@microninstruments.com

TITLE: **M-GAGE**

SIZE	DWG. NO.	REV
A	MI-WEB	-

SCALE: 64:1 WEIGHT: SHEET 1 OF 1

Below are Descriptions and Illustrations of the Gold or Aluminum wire bonds used in the manufacturing of P-doped Silicon semiconductor strain gages and N- doped temperature sensors at Micron Instruments.

Types of Bonding

- ◆ PARALLEL GAP
- ◆ BALL BOND
- ◆ WEDGE BOND

PARALLEL GAP

Parallel gap bonding is a resistance weld.

This weld uses High current and two Tungsten conductors spaced a short distance apart on the gold pads. Pressing the 0.002 diameter pure gold lead wire to the pads under high current welds the gold wire to the gold pad creating the bond. The leads come off the gage axially and are a minimum length of .050". Commonly used on the Straight "Bar", "U" or "M" shaped gages.



PARALLEL GAP BOND ON A "BAR" SHAPED GAGE

<p>PROPRIETARY AND CONFIDENTIAL THE INFORMATION CONTAINED IN THIS DRAWING IS THE SOLE PROPERTY OF MICRON INSTRUMENTS. REPRODUCTION IN PART OR AS A WHOLE WITHOUT THE WRITTEN PERMISSION OF MICRON INSTRUMENTS IS PROHIBITED.</p>						
	UNLESS OTHERWISE SPECIFIED: DIMENSIONS ARE IN INCHES TOLERANCES: ANGULAR: MACH ± 0° 30' ONE PLACE DECIMAL: ± .030 TWO PLACE DECIMAL: ± .010 THREE PLACE DECIMAL: ± .005 ALL DIA: .005 MIN; .005 MAX	DRAWN: B ENGELM 9/19/14	NAME: B ENGLM	DATE: 9/19/14	MICRON INSTRUMENTS	
	SURFACE FINISH: 32/	CHECKED: D EVANS 9/19/14	ENG APPR:	MFG APPR:	4509 RUNWAY STREET SIMI VALLEY, CA 93063 (805) 522-4676 FAX (805) 522-4982 e-mail: sensors@microninstruments.com	
	INTERPRET GEOMETRIC TOLERANCING PER: MATERIAL: FINISH:	Q.A.	COMPANY:	TITLE: PARALLEL GAP BONDING		REV: -
NEXT ASSY: USED ON:	APPLICATION:	DO NOT SCALE DRAWING	SCALE: 64:1	WEIGHT:	SHEET 1 OF 1	

BALL BONDING

The ball bond is an elevated temperature ultrasonic bond.

Gold wire (0.0020 or 0.0015 diameter) is grabbed by a ceramic capillary, a tail of Gold wire is formed at the first cut off and forms a ball. This ball is vibrated as it presses onto the Gold or Aluminum pad fusing it to the pad as shown. Both gold wires are initially perpendicular to the gage then are bent 90° within .100". Wires are minimum length of .050". This bond is used when pad space is limited (small and miniature gages). Commonly used on the Straight "Bar", or "U" shaped gages.



BALL BOND ON A "BAR" SHAPED GAGE

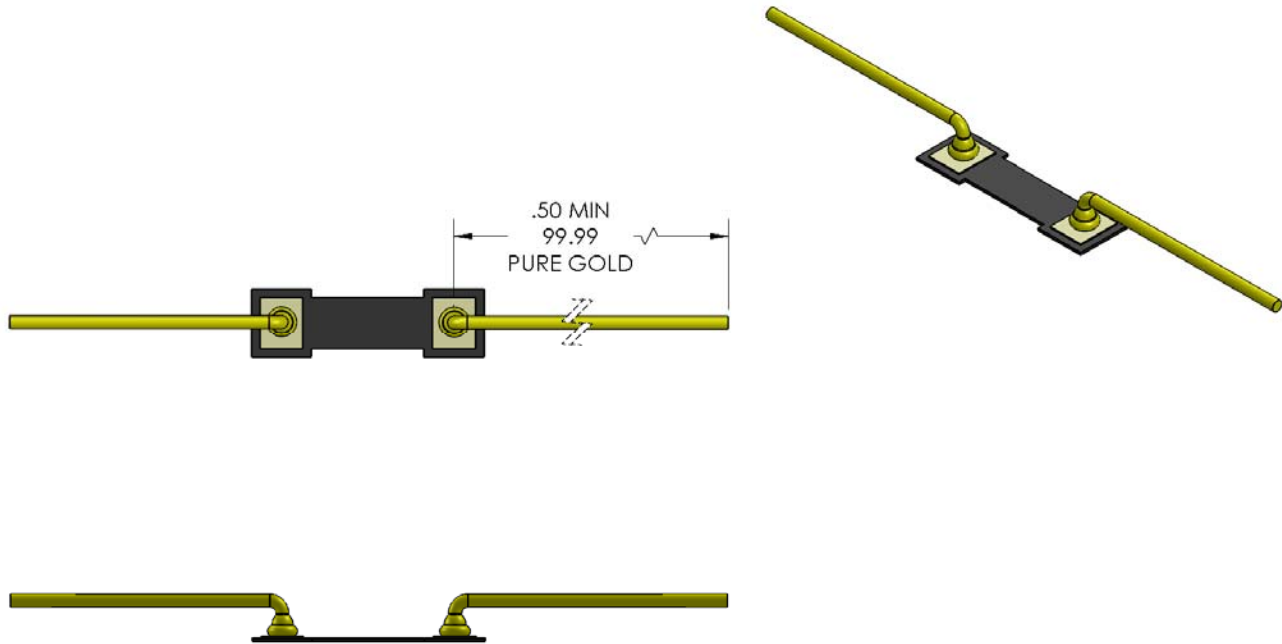

PROPRIETARY AND CONFIDENTIAL
THE INFORMATION CONTAINED IN THIS DRAWING IS THE SOLE PROPERTY OF MICRON INSTRUMENTS. REPRODUCTION IN PART OR AS A WHOLE WITHOUT THE WRITTEN PERMISSION OF MICRON INSTRUMENTS IS PROHIBITED.

		UNLESS OTHERWISE SPECIFIED: DIMENSIONS ARE IN INCHES TOLERANCES: ANGULAR: MACH ± 0° 30' ONE PLACE DECIMAL ± .030 TWO PLACE DECIMAL ± .010 THREE PLACE DECIMAL ± .005 ALL DIA. 0.005 TR. RADII: 0.005 MAX	NAME	DATE
		SURFACE FINISH 30/ INTERPRET GEOMETRIC TOLERANCING PER:	B ENGBLOM	9/19/14
		MATERIAL	D EVANS	9/19/14
NEXT ASSY	USED ON	FINISH	ENG APPR.	
APPLICATION		DO NOT SCALE DRAWING	MFG APPR.	
			Q.A.	
			COMPANY:	

MICRON INSTRUMENTS		
4509 RUNWAY STREET SIMI VALLEY, CA 93063 (805) 522-4676 FAX (805) 522-4982 email: sensors@microninstruments.com		
TITLE: BALL BONDING		
SIZE	DWG. NO.	REV
A	EXAMPLE	-
SCALE: 64:1 WEIGHT:		SHEET 1 OF 1

WEDGE BOND

An ultrasonic bond fusing the gage lead wire onto the pad with pressure and vibration.

Although this weld can be used with Gold or Aluminum pads and with Gold or Aluminum lead wires, Micron Instruments currently stocks only one gage, the 0.047-025-1000PU with 0.0030 diameter pure Aluminum leads that are a minimum of .050" long wedge bonded onto aluminum pads. This gage is operational up to 1000 degrees F. Commonly used on the "U" shaped gages.



WEDGE BOND ON A "U" SHAPED GAGE

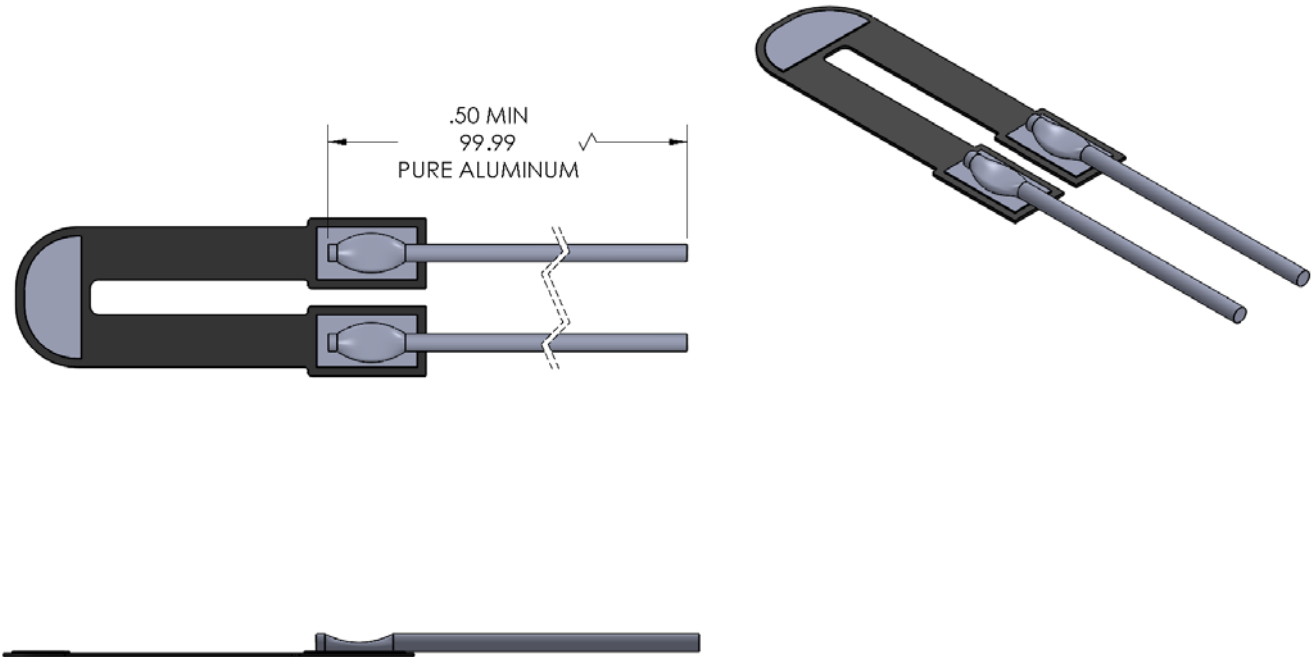

PROPRIETARY AND CONFIDENTIAL
THE INFORMATION CONTAINED IN THIS DRAWING IS THE SOLE PROPERTY OF MICRON INSTRUMENTS. REPRODUCTION IN PART OR AS A WHOLE WITHOUT THE WRITTEN PERMISSION OF MICRON INSTRUMENTS IS PROHIBITED.

		UNLESS OTHERWISE SPECIFIED:		NAME	DATE
		DIMENSIONS ARE IN INCHES		B ENGBLOM	9/19/14
		TOLERANCES:		CHECKED	D EVANS
		ANGULAR: $\pm 0^{\circ} 30'$		ENG APPR.	
		ONE PLACE DECIMAL $\pm .020$		MFG APPR.	
		TWO PLACE DECIMAL $\pm .010$		Q.A.	
		THREE PLACE DECIMAL $\pm .005$		COMPANY:	
		ALL DIA. 0.005 TIR. RADII 0.005 MAX			
		SURFACE FINISH ∇			
		INTERPRET GEOMETRIC TOLERANCING PER:			
		MATERIAL			
		FINISH			
NEXT ASSY	USED ON				
APPLICATION		DO NOT SCALE DRAWING			

MICRON INSTRUMENTS			
4509 RUNWAY STREET SIMI VALLEY, CA 93063 (805) 522-4676 FAX (805) 522-4982 email: sensors@microninstruments.com			
TITLE: WEDGE BONDING			
SIZE	DWG. NO.	REV	
A	EXAMPLE	-	
SCALE: 64:1	WEIGHT:		SHEET 1 OF 1