



# 6-Channel measuring amplifier GSV-6BT

## Operation manual

date:	23/05/2023
edition	Ba-gsv6bt-v1_7en
editor	SW
changes	Changelog page 16



## Measuring amplifier GSV-6BT

### Contents

Measuring amplifier GSV-6BT.....	4
Description.....	4
More functions.....	5
Software / Communication.....	6
Current consumption.....	8
Sensor connection.....	8
Pin assignment of GSV-6BT.....	9
Module Version GSV-6BT-LS.....	9
Pin assignment GSV-6BT M8.....	10
Strain gauge full bridges.....	11
Strain gauge half bridges.....	11
Strain gauge quarter bridge.....	12
Voltage input UE 0-10V.....	12
Input for incremental encoder.....	13
Battery and charging connector.....	13
Auxiliary voltage supply for active sensors or encoders.....	13
Digital inputs and outputs.....	14
Function of the LEDs.....	14
On/Off, Bluetooth States.....	14
Additional Documentation.....	15
Changelog.....	16

## Measuring amplifier GSV-6BT

6-channel measuring amplifier

Operation via Li-Ion battery 3.6V ... 4.2V

Integrated battery charging circuit

Inputs configurable for full, half, quarter bridges, 350-1000 ohms, 0 ... 10V

1x Bluetooth 4.0 (LE) (GATT) or Bluetooth Classic (SPP) configurable,

Data logger function with SDCard up to 7x 2000 measured values/s

Real Time Clock

Transmit measured value: 6x 1 measured values/s ... 500 measured values/s

Simultaneous acquisition of channels 1 to 3 and 2 to 6

Resolution <100 nV / V

Independent calculation of the 3 forces and torques for 6-axis sensors

Reading TEDS data on channel 1

Counter / frequency / speed measurement on channel 7

Two operating hours counters, one absolute and one resettable

## Description

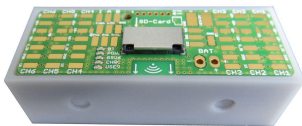

The GSV-6BT is a 6-channel measuring amplifier with Bluetooth interface and data logger function. There are two different model variants available: The module GSV-6BT-LS with solder pads and the version GSV-6BT M8 with housing.

The dimensions of the module are only 50mm x 20mm x 17mm. The GSV-6BT-LS has gold-plated solder pads for connecting the sensors, the battery and other I/O functions. For connection, strands with a cross-section of up to 0.09mm<sup>2</sup> (AWG28) are suitable.

The version GSV-6BT M8 has the same functionality, but all connections are done by terminal strips and a rechargeable battery is build-in. The charging circuit can be powered by a supply voltage from 5V to 28VDC.

Both GSV-6BT have 6 measuring channels, of which the first channel is for bridge strain

gauges, while channels 2 to 6 can be individually configured as voltage input (single-ended) or as strain gauge bridge inputs. All channels can be connected as full- half or quarter-bridge configuration.

Another seventh channel for acquiring digital pulses is available for connecting incremental encoders or as an input for square wave signals.

The number of channels in the data transmission and file logging is configurable from 1 to 7 channels. Channel 7 is reserved for the connection of incremental encoders.

Channel 1 supports the reading of TEDS memories to automatically configure the scaling factor for the connected sensor. In addition, two configurable threshold outputs are available.

The Bluetooth connection supports BT Classic with Serial Port Profile (SPP) for complete configuration and continuous messaging, and BT LowEnergy (LE) with some services (GATT) for reading measurement data and battery voltage, e.g. via smartphone.

The measurement data can be recorded on a micro SD memory card, whereby there are various configuration options, such as continuous recording up to 3000 readings per second, long recording intervals with power management (battery saving mode) and digital input triggered recording. The recorded files can also be downloaded via Bluetooth SPP. A real-time clock creates timestamps in real time in the measurement data files.

## More functions

- The connected 3.7V lithium-ion battery can be charged by an integrated charging circuit.
- The temperature in the device and the battery voltage can be measured
- The simultaneous zeroing of all channels can be triggered via a digital input („tare“).
- The GSV-6BT is protected against vibration by a full encapsulation in a plastic housing.
- The configuration and acquisition of measurement data is possible with the program GSVmulti in the mode "BT Classic" with Serial Port Profile (SPP)
- The integrated Bluetooth module has its own microcontroller, which offers the self-programming user a simple scripting language to implement their own embedded applications. All functions of the GSV-6 CPU and all supported BT services as well as additional digital outputs and a dedicated LED are available.  
The factory-installed "BGscript" script serves the BT-LE requests and some SPP commands needed to perform the functionality described here. Communication with the GSV-6CPU is forwarded transparently.
- With the help of the microcontroller in the Bluetooth module, the BT transmission power and various power-on/off and battery saving modes can be set and the battery voltage can also be read out.



## Software / Communication

First, the GSV-6BT has to be searched and found (with the battery connected) by the Bluetooth driver of the BT adapter of the PC. The displayed device name of the GSV-6BT after it has been found is the same as the serial number of the device indicated on the nameplate. Some drivers may need to search manually for the supported services; SPP (BT classic) and BT-LE are supported.

To use the Windows program GSVmultichannel, e.g. for configuration, the BT driver for SPP must create a virtual COM port whose number should be known (otherwise look in the Windows Device Manager), so that the program can connect to the GSV-6BT. Click on the button "Add Channel".

The BT device search process does not need to be repeated later if the same device is reopened with the same PC, and the COM port number will remain the same. If the host PC or another GSV-6BT is changed, the search must be carried out again.

After connecting to the software or opening the COM port, the GSV-6BT is fully turned on, the blue LED that indicates the active BT connection is lit as well as the green that indicates that the GSV-6CPU analog amplifier electronics are on.

With GSVmultichannel can be configured among many other things whether the GSV-6CPU should remain switched on after closing the BT connection or not. If it is off, this saves battery charge, if it is on, e. g. the measurement data can be recorded permanently.

This and other Bluetooth-specific settings can be found in the program under:

Menu bar → Device → Advanced Settings → Interface → Bluetooth Settings

Settings for recording can be found here:

Menu bar → Device → Advanced Settings → Administration → Measuring Value Logger → Settings

There you can also open a file browser for the GSV-6BT SD card.

GSVmultichannel also provides a context help, which can be activated in the main window via Menubar -> Help.

**After the first or new connection of the battery (Li-ion battery), the real-time clock should be set.** This is especially important when measuring data is to be recorded on an SD card. When you first turn it on after plugging in a new battery or when it has been recharged and had been completely empty, the red GSV6 LED flashes quickly <sup>1</sup>.

With GSVmultichannel, the real-time clock can be set here:

Menu bar → Device → Advanced Settings → Administration

On the right side under "Device RTC time", click on the "Sync" button next to the date / time display.

---

<sup>1</sup> it start with device software version 3.17



GSVmultichannel can also be used to reset one of the two operating hours counters at the same location. The operating hours counters work independently of the RTC.

The functions of the data logger and the frequency / tachometer or counter are described in separate documents which can be downloaded from the product page at [www.me-systeme.de](http://www.me-systeme.de).

For self-programming users, a Windows function library (MEGSV8w32.dll) with annotated C header is available for application programming, also with a LabView © library with wrapper VIs for this DLL.

For the use of the GSV-6BT in "Bluetooth LE" mode, a Windows app is available. In the Bluetooth LE mode, the GSV-6BT is compatible with general BT-LE/GATT apps, e.g. for use with mobile phones.



## Current consumption

			59 sec. GSVonoff=2 Timeintervall>0 Periodical Logger seconds	2 min. GSVonoff=2 Timeintervall=0 Periodical Logger Minutes
BT LE BTmode=0	GSV off	1,2 mA	48 mA	1,2 mA
	GSV on	53 mA	n.a.	n.a.
BT Classic SPP BTmode=1	GSV off	0,78 mA	48 mA	1,2 mA
	GSV on	62,3 mA	n.a.	n.a.

After the mode changed from BT-Classic to BT-LE: 0.78 mA

After the mode changed from BT-LE to BT-Classic: 1.2 mA

The **GSV-6BT M8** has a build-in battery of **6800 mAh**. For example, when logging to SDcard with Bluetooth disconnected and data frequency = 10 rows/s (consumption about 60mA), data can be recorded for up to 110 hours.

## Sensor connection

To correctly display and record physical values, the measurement amplifier must be configured based on the connected sensor. If the sensor on Channel 1 is equipped with TEDS and wired properly, it will use the sensor configuration stored in the TEDS data. This includes the system scaling ("AnalogOutScale"), the user scaling and the unit. The usage of TEDS can be deactivated in GSVmultichannel under menu bar -> sensor -> TEDS ... In this dialog the TEDS data can also be read and displayed.

Sensors without TEDS can be configured with GSVmultichannel via the Configuration tab -> Input Type and -> Scaling.



## Pin assignment of GSV-6BT

### Module Version GSV-6BT-LS

The connection of the sensors, the rechargeable battery and the voltage for charge / trickle charging of the rechargeable battery is done via solder pads.

For the configuration of the inputs to strain gage half bridges or strain gage quarter bridges, solder bridges have to be closed.

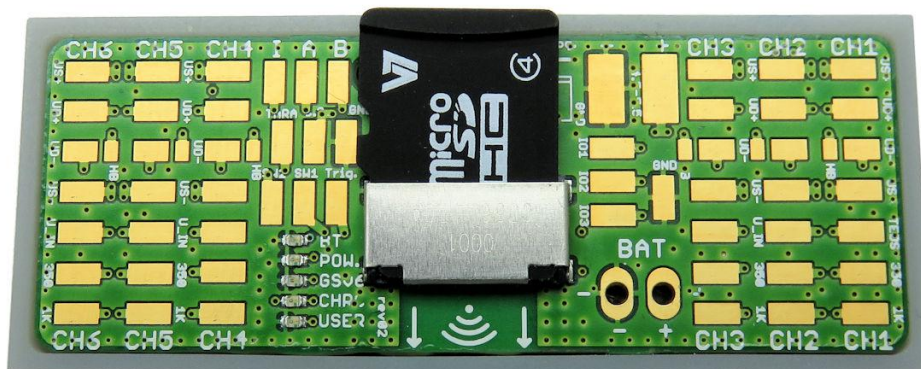
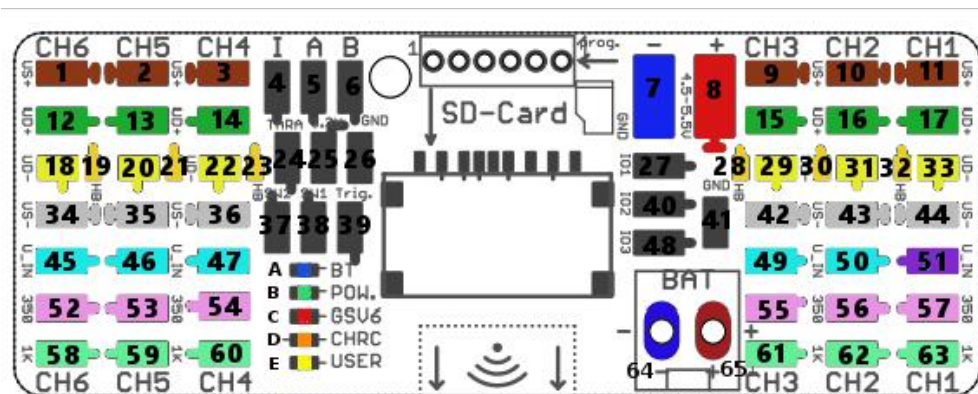

## Pin assignment GSV-6BT M8

The connection of the sensors is done by screw terminals, optional digital I/O connections by push-clamp terminals.

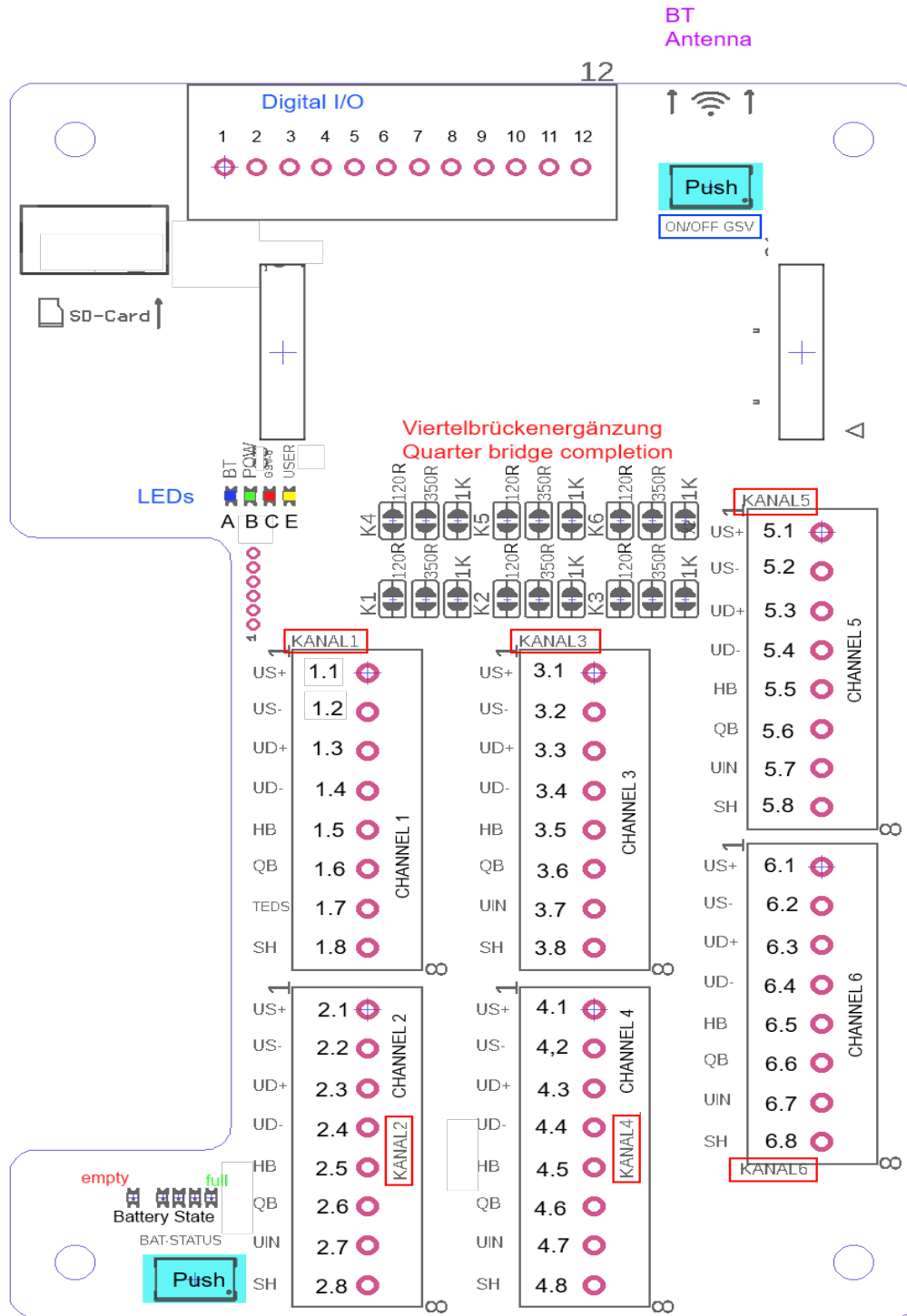

With the push key below, the battery charging state can be checked. With the push key above, the measuring core GSV-6CPU can be power on/off (if configured by software).

## Strain gauge full bridges

Designation	GSV-6BT Module						GSV-6BT M8					
	Ch 1	Ch 2	Ch 3	Ch 4	Ch 5	Ch 6	Ch 1	Ch 2	Ch 3	Ch 4	Ch 5	Ch 6
Positive bridge supply $U_{s+}$	11	10	9	3	2	1	1.1	2.1	3.3	4.1	5.1	6.1
Positive bridge output $U_{d+}$	17	16	15	14	13	12	1.3	2.3	3.3	4.3	5.3	6.3
Negative bridge output $U_{d-}$	33	31	29	22	20	18	1.4	2.4	3.4	4.4	5.4	6.4
Negative bridge supply $U_{s-}$	44	43	42	36	35	34	1.2	2.2	3.2	4.2	5.2	6.2

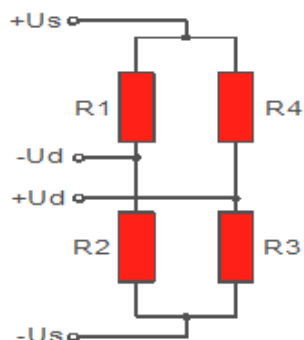

## Strain gauge half bridges

Designation	GSV-6BT Module						GSV-6BT M8					
	Ch 1	Ch 2	Ch 3	Ch 4	Ch 5	Ch 6	Ch 1	Ch 2	Ch 3	Ch 4	Ch 5	Ch 6
Positive bridge supply $U_{s+}$	11	10	9	3	2	1	1.1	2.1	3.3	4.1	5.1	6.1
Positive bridge supply $U_{d+}$	17	16	15	14	13	12	1.3	2.3	3.3	4.3	5.3	6.3
Set a bridge from ( $U_{d-}$ )...	33	31	29	22	20	18	1.4	2.4	3.4	4.4	5.4	6.4
... to (half bridge) HB	32	30	28	23	21	19	1.5	2.5	3.5	4.5	5.5	6.5
Negative bridge supply $U_{s-}$	44	43	42	36	35	34	1.2	2.2	3.2	4.2	5.2	6.2

The active strain gauges R3 and R4 are connected to the terminals +Us, +Ud and -Us. The internal half-bridge R1, R2 is activated with a bridge connection from HB to Ud-.

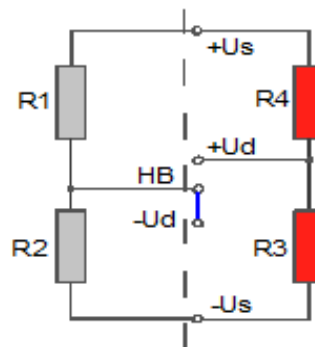

## Strain gauge quarter bridge

Designation	GSV-6BT Module						GSV-6BT M8					
	Ch 1	Ch 2	Ch 3	Ch 4	Ch 5	Ch 6	Ch 1	Ch 2	Ch 3	Ch 4	Ch 5	Ch 6
Positive bridge output Ud+	17	16	15	14	13	12	1.3	2.3	3.3	4.3	5.3	6.3
Set a bridge from (Ud-)...	33	31	29	22	20	18	1.4	2.4	3.4	4.4	5.4	6.4
... to (half bridge) HB	32	30	28	23	21	19	1.5	2.5	3.5	4.5	5.5	6.5
350 Ohm quarter bridge Q350 / QB	57	56	55	54	53	52	1.6	2.6	3.6	4.6	5.6	6.6
1000 Ohm quarter bridge Q1k	63	62	61	60	59	58	1.6*	2.6*	3.6*	4.6*	5.6*	6.6*

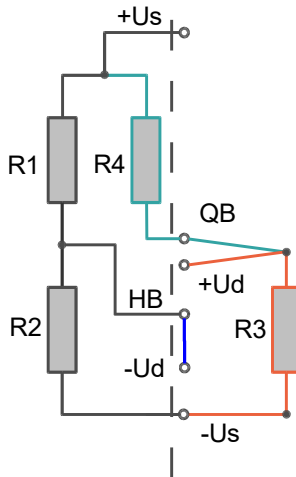

The active strain gauge R3 is connected in 3-wire technology to the terminals Ud+, QB and -Us.

The internal half-bridge R1, R2 is activated with a bridge connection from HB to Ud-.

\*With GSV-6BT M8, when using quarter bridges of 120 or 1000 Ohms, solder jumper(s) must be changed for the appropriate channel(s). By default, quarter bridge is set to 350 Ohms.

Only one of the three solder jumpers for quarter bridge completion must be closed for each channel, the other two must be left open.



## Voltage input UE 0-10V

Designation	GSV-6BT Module						GSV-6BT M8					
	Ch 1	Ch 2	Ch 3	Ch 4	Ch 5	Ch 6	Ch 1	Ch 2	Ch 3	Ch 4	Ch 5	Ch 6
Input ground (Us-)	-	43	42	36	35	34	-	2.2	3.2	4.2	5.2	6.2
Voltage input UE	-	50	49	47	46	45	-	2.7	3.7	4.7	5.7	6.7

The analog input UE (single ended) measures voltages 0 ... 10V with respect to the US. The potential of US corresponds to the potential of the negative battery voltage. Single-ended inputs are only available for channels 2-6.<sup>2</sup>



With GSV-6BT M8, the **cable shield** can be connected to 1.8, 2.8, ... 6.8. With the module version it can be connected to the minus pole of the battery or charging connector (Pad 7).

<sup>2</sup> The voltage input is not calibrated

### Input for incremental encoder

	GSV-6BT Module	GSV-6BT M8
Designation	Pad No.	Digital I/O No.
Incremental encoder / I_index (Home/Index/Z)	4	10
Incremental encoder / A-signal	5	11
Incremental encoder / B-signal	6	12
Ground	26	6

### Battery and charging connector

	GSV-6BT Module	GSV-6BT M8
Designation	Pad No.	Connector
Battery charging connection ground		M8 connector: Blue (3)
Battery charging V+ 4.5 – 5.5V, 0.5A		Not available
Battery charging V+ 5 - 28V, 2A	Not available	M8 connector: Brown (1)
Battery negative pole	64	(internal only)
Battery positive pole	65	(internal only)
Tare (Zero Setting, software configurable) to trigger set zero, connect with GND for at least 2s	24	Digital I/O No. 1

### Auxiliary voltage supply for active sensors or encoders

	GSV-6BT Module	GSV-6BT M8
Designation	Pad No.	Digital I/O No.
3,3 V Voltage output (10mA max)	25	3
GND	26	6



## Digital inputs and outputs

	GSV-6BT Module	GSV-6BT M8
Designation	Pad No.	Digital I/O No.
Threshold output 2	37	5
Threshold output 1	38	2
Trigger input	39	4
IO_1 / PB4 BT121	27	7
IO_2 / PB5 BT121	40	8
GND_IO	41	6
IO_3 / PB6 BT121 / OnOff Key	48	-
TEDS communication pin	51	Channel 1 terminal: 1.7

## Function of the LEDs

Designation	Description	Nr.
BT	Bluetooth Status: On: connected	A
POW.	GSV-6CPU (measuring app) On/Off	B
GSV6	GSV-6CPU Status: flash codes, e.g. for TEDS. constantly on / slowly flashing: File open on SD card for writing. <b>Do NOT remove the card!</b>	C
CHRG	Battery charging indicator	D
USER	IO_4 by BGscript freely programmable LED	E

## On/Off, Bluetooth States

When connecting successfully via Bluetooth (classic or BLE) to the GSV-6BT, the measuring hardware "GSV-6CPU" is always switched on, regardless of the configured on/off mode or the actual on/off state.

However, the on/off mode of the measuring hardware when the Bluetooth connection is not active, is configurable. With some applications, like recording data on SD card, it's desirable that the measuring hardware remains on, even with Bluetooth connection closed.

Even in "off" state, the RTC clock remains powered as long as the battery is connected, because in fact, it's a standby state with current consumption of about 200µA.

GSVonOffMode	Value	Function, if BT connection closed
GSVoff	0	GSV-6CPU Device switches off
GSVon	1	GSV-6CPU Device remains on
Auto-Triggered	2	Periodical Logger (used for data period > 3s; battery saving)
On/Off by Key	3	ON/OFF GSV-6CPU by push key (IO_3), present with M8 version <sup>3</sup>
On/Off by Switch	4	ON/OFF GSV-6CPU by Switch at IO_3 <sup>3</sup>

This GSVonOffMode can be changed using GSVmulti under Menu bar -> Device -> Advanced Settings -> Interface -> Bluetooth Settings. The corresponding BGscript commands are SetGSVonoff and GetGSVonoff.

The Bluetooth Mode can also be changed between Classic = SPP or LowEnergy (Gatt) in this GSVmulti dialog. When changed, it's valid after the Program is closed, i.e. after the actual Bluetooth connection is terminated.

## Additional Documentation

The communication protocol using Bluetooth Classic (SPP) is generally identical to the serial protocol that is described in [GSV-ProtocolDefinitionEN.pdf](#).

Additionally, the BGscript has some own commands that are separately described in [ba-gsv6bt-commands.pdf](#).

The communication with the GSV-6BT in Bluetooth LowEnergy (Gatt) Mode is described in [ba-gsv6bt-gattservices\\_en.pdf](#)

---

<sup>3</sup> Available from BGscript version 1.00



## Changelog

version	date	amendments
ba-gsv6bt-v1.0.odt	25.02.18	First german version (Kab)
ba-gsv6bt-v1.1.odt	05.03.18	description extended (SW)
ba-gsv6bt-v1.2.odt	02.04.18	Power consumption added (Kab)
ba-gsv6bt-v1.3	03.04.18	Added (SW)
ba-gsv6bt-v1.0-en.odt	13.06.18	first english version (AE)
ba-gsv6bt-v1.3-en.odt	19.06.18	english version edited and added contents (AK)
ba-gsv6bt-v1.4-en.odt	28.06.19	At channel 1: only Bridges; typos
ba-gsv6bt-v1_5en.odt	2021/01/20	Clarifications, language issues, updates (SW)
ba-gsv6bt-v1_6en	2022/05/02	Updated for GSV-6BT M8 (preliminary) (SW)
ba-gsv6bt-v1_7en	2022/08/02	reviewed, On/Off Bluetooth States (SW)



Subject to changes.

All details describe our products in a general form.

They constitute no warranty of characteristics as defined by § 459, Paragraph 2 of the German Civil Code nor ground for liability.

Made in Germany

Copyright © 2023  
ME-Meßsysteme GmbH  
Printed in Germany