

Anschraubfläche
Stator

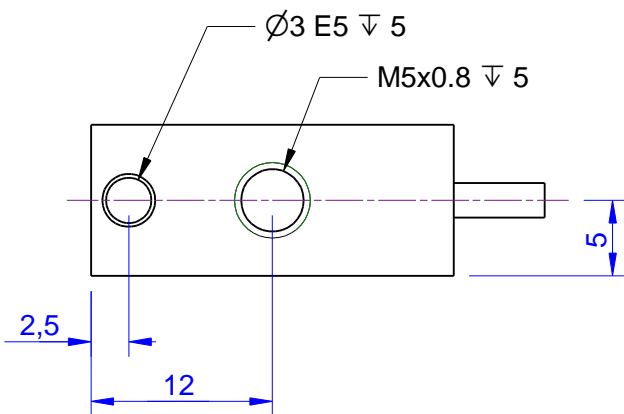

Anschraubfläche
Messplattform

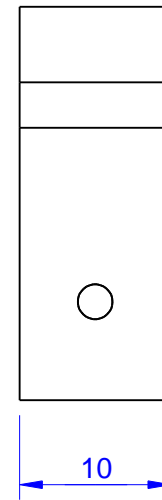
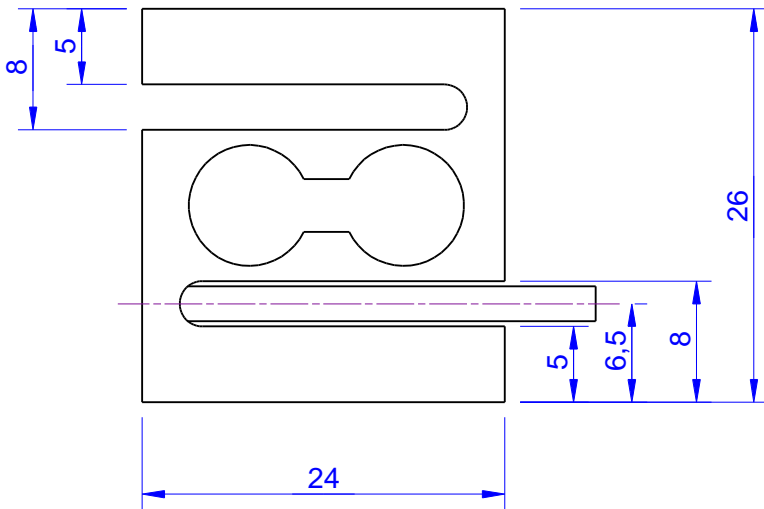
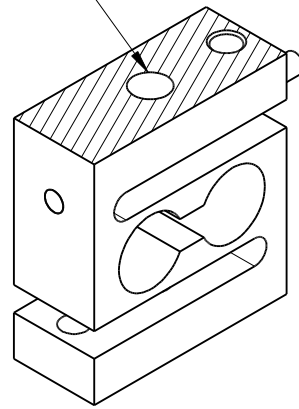
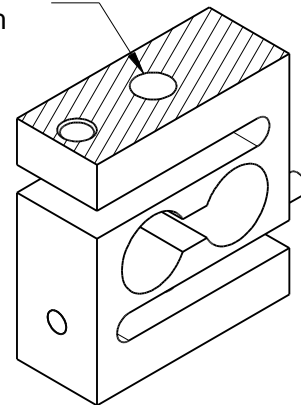

Kanten o. Maßangabe DIN 6784		Innenkanten ± 0.5		Außenkanten ± 0.3		Allgemeintoleranzen ISO 2768-mK Oberfläche: DIN EN ISO 1302 ($\sqrt{Rz16}$)		Maßstab: 1,5:1		Gewicht: 12g		ME-Art.:	
Gewindesenkungen DIN 76 unter 90° bis 120° bis Gewindeaußendurchmesser								Halbzeug: -					
								Material:					
								Bauteilbenennung:					
								KD24s 2N-20N					
								K-Modell					
								Zeichnungsnummer:				Blatt: -	
								KD24s_2N-20N_000_K(a)				- Blätter	
Zust.		Änderung		Datum		Name		Ersatz für: -				Format: A	
								ME-Meßsysteme GmbH Tel.: +49 3302 7862060 www.me-systeme.de					
								Schutzvermerk DIN 34 beachten					